

General-Purpose Linear ICs

- Operational Amplifier ICs (Op Amp ICs) & Comparator ICs ● 118
 - Intelligent Power Devices (IPDs) ● 121
 - Interface Drivers ● 124
 - Motor Drivers ● 127
 - Power Supply ICs ● 132
- Small-Signal MMICs (Radio-Frequency Cell Packs) ● 142

Datasheet.Global

Operational Amplifier ICs (Op Amp ICs) & Comparator ICs

Operational Amplifier ICs (Op Amp ICs) & Comparator ICs (Bipolar, Single-Circuit Type)

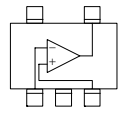
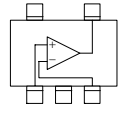
Part Number	Package	Marking	Functions	Features	Operating Voltage (V)	◆ Internal Connections
TA75S393F	SMV	TA	Bipolar comparator	Single/dual power supply, open-collector output	2 to 36 or ± 1 to ± 18	
TA75S01F	SMV	SA	Bipolar Op Amp	Single/dual power supply, unity gain stable	3 to 12 or ± 1.5 to ± 6	
TA75S558F	SMV	SB		Dual power supply	± 4 to ± 18	

- Note that input pin configurations of the single op amp and comparator ICs differ.
- Contact the Toshiba sales representative for information about RoHS compliance before you purchase any components.
- ◆ The internal connection diagrams only show the general configurations of the circuits.

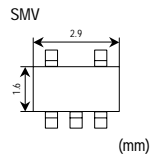

(Bipolar, Dual-Circuit Type)

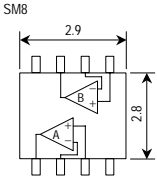
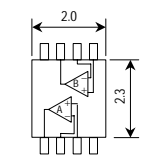
Part Number	Package	Marking	Functions	Features	Operating Voltage (V)	◆ Internal Connections (Unit: mm)
TA75W393FU	SM8	5W393	Bipolar comparator	Single/dual power supply, open-collector output	2 to 36 or ± 1 to ± 18	
TA75W01FU	SM8	5W01	Bipolar Op Amp	Single/dual power supply, unity gain stable	3 to 12 or ± 1.5 to ± 6	
TA75W558FU	SM8	5W558		Dual power supply	± 4 to ± 18	

- Contact the Toshiba sales representative for information about RoHS compliance before you purchase any components.
- ◆ The internal connection diagrams only show the general configurations of the circuits.

(CMOS, Single-Circuit Type)

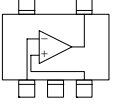
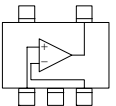
Part Number	Package	Marking	Functions	Features	Operating Voltage (V)	◆ Internal Connections	
TC75S56F	SMV	TC	CMOS comparator	Single/dual power supply, push-pull output, ultra-low current consumption	1.8 to 7 or ±0.9 to ±3.5		
TC75S56FU	USV						
TC75S56FE	ESV						
TC75S57F	SMV	TD		Single/dual power supply, push-pull output, low current consumption	1.8 to 7 or ±0.9 to ±3.5		
TC75S57FU	USV						
TC75S57FE	ESV						
TC75S58F	SMV	TE		Single/dual power supply, open-drain output, ultra-low current consumption	1.8 to 7 or ±0.9 to ±3.5		
TC75S58FU	USV						
TC75S58FE	ESV						
TC75S58AFE *	ESV	TG		Single/dual power supply, open-drain output, ultra-low current consumption powerdown power outputs	1.8 to 7 or ±0.9 to ±3.5		
TC75S58AFC *	CST6C						
TC75S59F	SMV	TF		Single/dual power supply, open-drain output, low current consumption	1.8 to 7 or ±0.9 to ±3.5		
TC75S59FU	USV						
TC75S59FE	ESV						
TC75S59AFE *	ESV	TH	Single/dual power supply, open-drain output, low current consumption powerdown power outputs	1.8 to 7 or ±0.9 to ±3.5			
TC75S59AFC *	CST6C						
TC75S51F	SMV	SC	CMOS op amp	Single/dual power supply, low-voltage operation	1.5 to 7 or ±0.75 to ±3.5		
TC75S51FU	USV						
TC75S51FE	ESV						
TC75S54F	SMV	SE		Single/dual power supply, low-voltage operation, low current consumption	1.8 to 7 or ±0.9 to ±3.5		
TC75S54FU	USV						
TC75S54FE	ESV						
TC75S55F	SMV	SF		Single/dual power supply, low-voltage operation, ultra-low current consumption	1.8 to 7 or ±0.9 to ±3.5		
TC75S55FU	USV						
TC75S55FE	ESV						
TC75S60F	SMV	SH		Single/dual power supply, high slew rate, high fr, low-voltage operation, low current consumption	1.8 to 7 or ±0.9 to ±3.5		
TC75S60FU	USV						
TC75S101F *	SMV	SJ		CMOS op amp with a full range of input and output voltages	Single/dual power supply, full range of input and output voltages, low offset voltage, low bias current, low-voltage operation		1.5 to 5.5 or ±0.75 to ±2.75
TC75S101FU *	USV						
TC75S101FE *	ESV						

• Note that input pin configurations of the single op amp and comparator ICs differ.

*: New product

• Contact the Toshiba sales representative for information about RoHS compliance before you purchase any components.

◆ The internal connection diagrams only show the general configurations of the circuits.

SMV

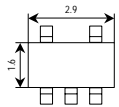

USV

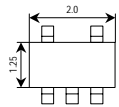

ESV

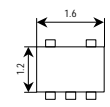

CST6C

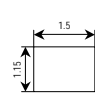

(mm)

(CMOS, Dual-Circuit Type)

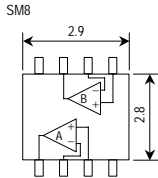
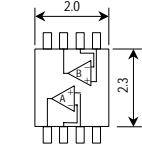
Part Number	Package	Marking	Functions	Features	Operating Voltage (V)	◆Internal Connections (Unit: mm)	
TC75W56FU	SM8	5W56	CMOS comparator	Single/dual power supply, push-pull output, ultra-low current consumption	1.8 to 7 or ± 0.9 to ± 3.5		
TC75W56FK	US8				± 0.9 to ± 3.5		
TC75W57FU	SM8	5W57		Single/dual power supply, push-pull output, low current consumption	1.8 to 7 or ± 0.9 to ± 3.5		
TC75W57FK	US8				± 0.9 to ± 3.5		
TC75W58FU	SM8	5W58		CMOS op amp	Single/dual power supply, open-drain output, ultra-low current consumption		1.8 to 7 or ± 0.9 to ± 3.5
TC75W58FK	US8						± 0.9 to ± 3.5
TC75W59FU	SM8	5W59	Single/dual power supply, open-drain output, low current consumption		1.8 to 7 or ± 0.9 to ± 3.5		
TC75W59FK	US8				± 0.9 to ± 3.5		
TC75W51FU	SM8	5W51	CMOS op amp		Single/dual power supply, low-voltage operation	1.5 to 7 or ± 0.75 to ± 3.5	
TC75W51FK	US8					± 0.75 to ± 3.5	
TC75W54FU	SM8	5W54		Single/dual power supply, low-voltage operation, low current consumption	1.8 to 7 or ± 0.9 to ± 3.5		
TC75W54FK	US8				± 0.9 to ± 3.5		
TC75W55FU	SM8	5W55		Single/dual power supply, low-voltage operation, ultra-low current consumption	1.8 to 7 or ± 0.9 to ± 3.5		
TC75W55FK	US8				± 0.9 to ± 3.5		
TC75W60FU	SM8	5W60	Single/dual power supply, high slew rate, high fr, low-voltage operation, low current consumption	1.8 to 7 or ± 0.9 to ± 3.5			
TC75W60FK	US8			± 0.9 to ± 3.5			

• Contact the Toshiba sales representative for information about RoHS compliance before you purchase any components.

◆The internal connection diagrams only show the general configurations of the circuits.

Intelligent Power Devices (IPDs)

60 V Series

Part Number	Package	Features	Characteristics										Operating Temperature Topr (°C)	Operating Supply Voltage (V)	
			Outlines	Junction (Channel) Temperature Tj (°C)	Power Dissipation Pd (W)	Protective Functions			Diagnostic Functions						Input/Output
						Overcurrent Is (A)	Over-temperature Ts (°C)	Overvoltage Vs (V)	Short Load	Open Load	Over-temperature	Overvoltage			
TPD1018F	SSOP-10	High-side switch	V _{DSS} 60 V I _o 0.5 A R _{Ds(ON)} = 0.8 Ω max	150	0.3	1.5 typ.	160 typ.	30 typ.	○ DIAG L	—	○ DIAG L	○ DIAG L	H/H	−40 to 125	5 to 25
TPD1024S	PW-Mold	Low-side switch	V _{Ds(DC)} 40 V I _o 1.5 A R _{Ds(ON)} = 0.5 Ω max		1	3.5 typ.	160 typ.	Active clamp 40 min	—	—	—	—	H/L	−40 to 85	Up to 18
TPD1024AS	TPS	Low-side switch	V _{Ds(DC)} 40 V I _o 1.5 A R _{Ds(ON)} = 0.5 Ω max		1.2	3.5 typ.	160 typ.	Active clamp 40 min	—	—	—	—	H/L	−40 to 85	Up to 18
TPD1030F	SOP-8	2-ch low-side switch	V _{Ds(DC)} 40 V I _o 1 A R _{Ds(ON)} = 0.6 Ω max		2.0 (t = 10 s) (mounted on board)	1 min	160 typ.	Active clamp 40 min	—	—	—	—	H/L	−40 to 110	Up to 40
TPD1031AF	TO-220SM	Low-side switch	V _{Ds(DC)} 50 V I _o 8 A R _{Ds(ON)} = 0.065 Ω max		50 (T _c = 25°C)	8 min	160 typ.	Active clamp 50 min	—	—	—	—	H/L		Up to 18
TPD1032F	SOP-8	2-ch low-side switch	V _{Ds(DC)} 20 V I _o 3 A R _{Ds(ON)} = 0.4 Ω max		2.0 (t = 10 s) (mounted on board)	3 min	160 typ.	Active clamp 40 min	—	—	—	—	H/L		Up to 20
TPD1033F	SOP-8	High-side switch	V _{DSS} 60 V I _o 4 A R _{Ds(ON)} = 0.22 Ω max		2.4 (t = 10 s) (mounted on board)	6 typ.	160 typ.	—	○ DIAG L	○ DIAG H	○ DIAG L	—	H/H		5 to 18
TPD1034F	SOP-8	High-side switch	V _{DSS} 60 V I _o 8 A R _{Ds(ON)} = 0.08 Ω max		12 typ.	160 typ.	—	○ DIAG L	○ DIAG H	○ DIAG L	—	H/H			
TPD1036F	SOP-8	2-ch low-side switch	V _{Ds(DC)} 30 V I _o 1.5 A R _{Ds(ON)} = 0.5 Ω max		2.0 (t = 10 s) (mounted on board)	1.5 min	160 typ.	Active clamp 40 min	—	—	—	—	H/L	Up to 30	
TPD1037BS	LSTM	Low-side switch	V _{Ds(DC)} 40 V I _o 1.5 A R _{Ds(ON)} = 0.25 Ω max		0.9	In-rush 10 typ. Shorted load 3 typ.	160 typ.	Active clamp 40 min	—	—	—	—	H/L	−40 to 85	Up to 40
TPD1038F	SOP-8	High-side switch	V _{DSS} 60 V I _o 3 A R _{Ds(ON)} = 0.12 Ω max		1.1 (mounted on board)	3 min	150 min	Active clamp 50 min	○ DIAG L	○ DIAG H	○ DIAG L	—	H/H	−40 to 110	6 to 18
TPD1039F	SOP-8	Low-side switch	V _{Ds(DC)} 45 V I _o 1.5 A R _{Ds(ON)} = 0.25 Ω max		1.1 (mounted on board)	5 typ.	125 min	Active clamp 45 min	—	—	—	—	H/L	−40 to 85	Up to 45
TPD1039S	LSTM	Low-side switch	V _{Ds(DC)} 45 V I _o 1.5 A R _{Ds(ON)} = 0.25 Ω max		0.9	5 typ.	125 min	Active clamp 45 min	—	—	—	—	H/L	−40 to 85	Up to 45
TPD1042F	SOP-8	High-side switch	V _{DSS} 60 V I _o 7 A R _{Ds(ON)} = 0.18 Ω max		1.1 (mounted on board)	7 min	150 min	—	○ DIAG L	○ DIAG H	○ DIAG L	—	H/H	−40 to 115	6 to 18
TPD1044F	PS-8	Low-side switch	V _{Ds(DC)} 41 V I _o 1 A R _{Ds(ON)} = 0.6 Ω max		0.9 (mounted on board)	1 min	160 typ.	Active clamp 41 min	—	—	—	—	H/L	−40 to 125	Up to 41
TPD1045F	SOP-8	Low-side switch	V _{Ds(DC)} 50 V I _o 5 A R _{Ds(ON)} = 0.1 Ω max		1.1 (mounted on board)	5 min	170 typ.	Active clamp 50 min	—	—	—	—	H/L	−40 to 125	up to 18
TPD1046F	SOP-8	2-ch Low-side switch	V _{Ds(DC)} 40 V I _o 3 A R _{Ds(ON)} = 0.2 Ω max		0.95 (mounted on board)	3 min	160 typ.	Active clamp 40 min	—	—	—	—	H/L	−40 to 125	up to 20
TPD1047F	SOP-8	High-side switch	V _{DSS} 60 V I _o 3 A R _{Ds(ON)} = 0.25 Ω max		1.1 (mounted on board)	6 typ.	165 typ.	—	Incorporates an amplifier for monitoring the output current				H/H	−40 to 125	6 to 18

• Contact the Toshiba sales representative for information about RoHS compliance before you purchase any components.

60 V Series (Continued)

Part Number	Package	Features	Characteristics											Operating Temperature Topr (°C)	Operating Supply Voltage (V)
			Outlines	Junction (Channel) Temperature Tj (°C)	Power Dissipation Pd (W)	Protective Functions			Diagnostic Functions				Input/Output		
						Overcurrent Is (A)	Over-temperature Ts (°C)	Overvoltage Vs (V)	Short Load	Open Load	Over-temperature	Overvoltage			
TPD1048F	TSSOP Advance	low-side switch	VDS(DC) 31 V Io 1.5 A RDS(ON) = 0.5 Ω max	150	30 (Tc = 25°C)	1.5 min	160 typ.	Active clamp 40 min	—	—	—	—	H/L	-40 to 85	up to 31
TPD1049F **	SOP Advance	high-side switch	VDS 60 V Io 8 A RDS(ON) = 0.08 Ω max		45 (Tc = 25°C)	14 typ.	160 typ.	—	○ DIAG L	○ DIAG H	○ DIAG L	—	H/H	-40 to 125	5 to 18
TPD1051F **	SOP Advance	2-ch high-side switch	VDS 60 V Io 3 A RDS(ON) = 0.2 Ω max		45 (Tc = 25°C)	3 min	165 typ.	—	○ DIAG L	○ DIAG H	○ DIAG L	—	H/H	-40 to 125	5 to 18
TPD2005F ☆	SSOP-24	8-ch high-side switch	VDD 45 V Io 1 A RDS(ON) = 1.2 Ω max		0.8	1.0 min	160 typ.	—	—	—	—	—	H/H	-40 to 85	8 to 40
TPD2007F ☆	SSOP-24	8-ch low-side switch	VDS(DC) 40 V Io 1 A RDS(ON) = 1.4 Ω max		0.8	1.0 min	160 typ.	Active clamp 40 min	—	—	—	—	H/L	—	up to 40
TPD7000AF ☆	SSOP-24	4-ch low-side Pw-MOSFET driver	VDS 25 V Io 20 mA max		0.5	Vds monitor 1.0 V typ.	—	Active clamp 35 V typ.	○ DIAG L	○ DIAG H	—	—	H/H (ENB = "H")	—	V _{DH} = 8 to 18 V _{DL} = 4.5 to 5.5
TPD7101F ☆	SSOP-24	2-ch high-side Pw-MOSFET driver (with built-in charge pump)	VDD 30 V Source current 0.1 A typ. Sink current 0.1 A typ.		0.8	Adjustable	—	○ (Undervoltage detected at 4.5 V max)	Overcurrent DIAG*1 L	—	—	—	H/H	-40 to 110	8 to 18
TPD7203F ☆	SSOP-24	Pw-MOSFET driver for 3-phase DC motors (built-in charge pump circuit)	VDD 30 V Source current 1 A max Sink current 1 A max		0.8	—	—	○ (Undervoltage detected at 6.0 V typ.)	—	—	—	○ FAULT H (only under-voltage)	H/H	-40 to 125	7 to 18
TPD7210F ☆	SSOP-24	Pw-MOSFET driver for 3-phase DC motors (built-in charge pump circuit)	VDD 30 V Source current 1 A max Sink current 1 A max	0.8	—	—	—	—	—	—	○ FAULT H (Note)	H/H	-40 to 125	V _{DDUV} to 18	

☆: Dry-packed

** : Under development

Note: Undervoltage: simultaneous high-and low-side turn-on.

- Contact the Toshiba sales representative for information about RoHS compliance before you purchase any components.

250 V / 500 V Series

Part Number	Package	Functions	Output Type	Characteristics				Rating (V/A)
				Features	Protective Functions			
					Overcurrent	Over-temperature	Undervoltage	
TPD4104K	HZIP23	6-input, low-side driver, high-side driver	3-phase full-bridge	High-voltage PWM DC brushless motor driver	○	○	○	500/2
TPD4104AK	HZIP23	6-input, low-side driver, high-side driver	3-phase full-bridge	High-voltage PWM DC brushless motor driver	—	○	○	500/2
TPD4105K	HZIP23	6-input, low-side driver, high-side driver	3-phase full-bridge	High-voltage PWM DC brushless motor driver	○	○	○	500/3
TPD4105AK	HZIP23	6-input, low-side driver, high-side driver	3-phase full-bridge	High-voltage PWM DC brushless motor driver	—	○	○	500/3
TPD4110AK	HZIP23	6-input, low-side driver, high-side driver, 3 shunt type	3-phase full-bridge	High-voltage PWM DC brushless motor driver	—	○	○	500/2
TPD4111K	HZIP23	Hall amp input, bootstrap circuit, PWM, 3-phase decoder	3-phase full-bridge	High-voltage PWM DC brushless motor driver	○	○	○	250/1
TPD4112K	HZIP23	Hall amp input, bootstrap circuit, PWM, 3-phase decoder	3-phase full-bridge	High-voltage PWM DC brushless motor driver	○	○	○	500/1
TPD4113K	HZIP23	6-input, low-side driver, high-side driver	3-phase full-bridge	High-voltage PWM DC brushless motor driver	○	○	○	500/1
TPD4113AK	HZIP23	6-input, low-side driver, high-side driver	3-phase full-bridge	High-voltage PWM DC brushless motor driver	—	○	○	500/1
TPD4120AK	DIP26	6-input, low-side driver, high-side driver, 3 shunt type	3-phase full-bridge	High-voltage PWM DC brushless motor driver	—	○	○	500/2
TPD4121K	DIP26	Hall amp input, bootstrap circuit, PWM, 3-phase decoder	3-phase full-bridge	High-voltage PWM DC brushless motor driver	○	○	○	250/1
TPD4122K	DIP26	Hall amp input, bootstrap circuit, PWM, 3-phase decoder	3-phase full-bridge	High-voltage PWM DC brushless motor driver	○	○	○	500/1
TPD4123K	DIP26	6-input, low-side driver, high-side driver, 3 shunt type	3-phase full-bridge	High-voltage PWM DC brushless motor driver	○	○	○	500/1
TPD4123AK	DIP26	6-input, low-side driver, high-side driver, 3 shunt type	3-phase full-bridge	High-voltage PWM DC brushless motor driver	—	○	○	500/1
TPD4124K	DIP26	6-input, low-side driver, high-side driver, 3 shunt type	3-phase full-bridge	High-voltage PWM DC brushless motor driver	○	○	○	500/2
TPD4124AK	DIP26	6-input, low-side driver, high-side driver, 3 shunt type	3-phase full-bridge	High-voltage PWM DC brushless motor driver	—	○	○	500/2
TPD4125K	DIP26	6-input, low-side driver, high-side driver, 3 shunt type	3-phase full-bridge	High-voltage PWM DC brushless motor driver	○	○	○	500/3
TPD4125AK	DIP26	6-input, low-side driver, high-side driver, 3 shunt type	3-phase full-bridge	High-voltage PWM DC brushless motor driver	—	○	○	500/3

- Contact the Toshiba sales representative for information about RoHS compliance before you purchase any components.

Interface Drivers

Transistor Arrays (Transistor Arrays/Interface Drivers)

Part Number	Package	Device Type	# of Circuits	Structure	Characteristics				Power Supply Voltage (V)
				Output Clamp Diodes	Output Breakdown Voltage (V)	Output Current (mA)	Input Resistor (Ω)	Recommended Input Voltage (V)	
TD62001APG/AFG	DIP16/SOP16	Darlington driver	7	○	50	500	NA	Arbitrary	—
TD62002APG/AFG	DIP16/SOP16	Darlington driver	7	○	50	500	10.5 k + 7 VZ.D.	14 to 15	—
TD62003APG/AFG	DIP16/SOP16	Darlington driver	7	○	50	500	2.7 k	5	—
ULN2003APG/AFWG ★	DIP16/SOL16	Darlington driver	7	○	50	500	2.7 k	5	—
ULQ2003APG/AFWG ★	DIP16/SOL16	Darlington driver	7	○	50	500	2.7 k	5	—
TD62004APG/AFG	DIP16/SOP16	Darlington driver	7	○	50	500	10.5 k	6 to 15	—
ULN2004APG/AFWG ★	DIP16/SOL16	Darlington driver	7	○	50	500	10.5 k	6 to 15	—
TD62006PG/FG	DIP14/SOP14	Darlington driver	6	○	22	150	20 k	6 to 20	—
TD62008APG/AFG	DIP16/SOP16	Darlington driver	7	○	50	400	20 k	6 to 20	—
TD62064APG/AFG/BP1G/BFG	DIP16/ HSOP16	High-current darlington driver	4	○	50/50/80/80	1500	230	5	—
TD62081APG/AFG	DIP18/SOP18	Darlington driver	8	○	50	500	NA	Arbitrary	—
TD62082APG/AFG	DIP18/SOP18	Darlington driver	8	○	50	500	10.5 k + 7 VZ.D.	14 to 25	—
TD62083APG/AFG/AFNG	DIP18/SOP18 SSOP18	Darlington driver	8	○	50	500	2.7 k	5	—
ULN2803APG/AFWG ★	DIP18/SOL18	Darlington driver	8	○	50	500	2.7 k	5	—
TD62084APG/AFG/AFNG	DIP18/SOP18 SSOP18	Darlington driver	8	○	50	500	10.5 k	6 to 15	—
ULN2804APG/AFWG ★	DIP18/SOL18	Darlington driver	8	○	50	500	10.5 k	6 to 15	—
TD62103FG	SOP16	Darlington driver	7		25	500	2.7 k	5	—
TD62104PG/FG	DIP16/SOP16	Darlington driver	7		25	500	10.5 k	6 to 15	—
TD62105FG	SOP16	Darlington driver	7		25	500	20 k	12 to 25	—
TD62107PG/FG	DIP16/ HSOP16	Darlington driver (with Enable pin)	4	○	45/35	750	LS, TTL- Compatible	5	17
TD62164APG/AFG/BPG/BFG	DIP16/ HSOP16	High-current, low-saturation driver	4	○	50/80/50/80	700	2 k	5 to 15	17
TD62304APG/AFG	DIP16/SOP16	Low-input-active darlington driver	7		50	500	14 k	5	7
TD62305APG/AFG/AFNG	DIP16/SOP16 SSOP16	Low-input-active darlington driver	7		50	500	14 k + D.	5	7
TD62307PG/FG	DIP16/SOP16	Low-saturation driver	7	○	20	150	20 k	5 to 18	20
TD62308APG/AFG/BPG/BFG	DIP16/ HSOP16	Low-input-active darlington driver	4	○	50/50/80/80	1500	4 k	5	10
TD62309PG/FG	DIP16/ HSOP16	Low-saturation driver	6	○	20	700	2 k	5	10
TD62318APG/AFG/BPG/BFG	DIP16/ HSOP16	Low-input-active, low-saturation driver	4	○	50/80/50/80	700	4 k	5	17
TD62381PG/FG/FNG	DIP18/SOP18 SSOP18	Low-saturation driver	8		15	500	2.7 k	5 to 18	7
TD62382APG/AFG/AFNG	DIP18/SOP18 SSOP18	Low-input-active, low-saturation driver	8		50	50	14 k	5 to 18	7
TD62383PG	DIP20	Low-input-active, low-saturation driver	8	○	10	500	14 k + D.	5 to 18	7
TD62384APG/AFG	DIP18/SOP18	Low-input-active darlington driver	8		50	500	14 k	5 to 18	7
TD62385AFG	SOP18	Low-input-active darlington driver	8		50	500	14 k + D.	5 to 18	7
TD62387APG/AFG/AFNG	DIP20/SOP20 SSOP20	Low-input-active darlington driver	8	○	50	500	14 k + D.	5 to 7	7
TD62501PG/FG	DIP16/SOP16	Single-transistor array (common emitter)	7		35	200	NA	Arbitrary	—
TD62502PG/FG/FNG	DIP16/SOP16 SSOP16	Single-transistor array (common emitter)	7		35	200	10.5 k + 7 VZ.D.	14 to 25	—
TD62503PG/FG/FNG	DIP16/SOP16 SSOP16	Single-transistor array (common emitter)	7		35	200	2.7 k	5	—
TD62504PG/FG/FNG	DIP16/SOP16 SSOP16	Single-transistor array (common emitter)	7		35	200	10.5 k	6 to 15	—
TD62505FG	SOP16	Single-transistor array (common collector)	7		35	-200	NA	Arbitrary	—
TD62506PG/FG	DIP16/SOP16	Single-transistor array (common collector)	7		35	-200	2.7 k	5	—

★ : Malaysia works product.

- Contact the Toshiba sales representative for information about RoHS compliance before you purchase any components.

Part Number	Package	Device Type	# of Circuits	Structure	Characteristics				Power Supply Voltage (V)
				Output Clamp Diodes	Output Breakdown Voltage (V)	Output Current (mA)	Input Resistor (Ω)	Recommended Input Voltage (V)	
TD62553SG	SIP9	Single-transistor array (common emitter)	4		25	150	2.7 k	5	—
TD62554SG	SIP9	Single-transistor array (common emitter)	4		25	150	10.5 k	6 to 15	—
TD62583APG/AFG	DIP18/SOP18	Single-transistor array (common emitter)	8		50	50	2.7 k	5	—
TD62592APG	DIP18	Single-transistor array (common emitter)	8		50	200	10.5 k + 7 VZ.D.	14 to 25	—
TD62593APG/AFNG	DIP18/SSOP18	Single-transistor array (common emitter)	8		50	200	2.7 k	5	—
TD62594AFNG	SSOP18	Single-transistor array (common emitter)	8		50	200	10.5 k	6 to 15	—
TD62597APG/AFG/AFNG	DIP18/SOP18 SSOP18	Single-transistor array (common emitter)	8	○	50	200	2.7 k	5	—
TD62598AFG/AFNG	SOP18 SSOP18	Single-transistor array (common emitter)	8	○	50	200	10.5 k	6 to 15	—
TD62601PG/FG	DIP16/SOP16	Threshold-free driver (inverted output)	6		20	10	1 M	4 to 18	20
TD62602PG/FG	DIP16/SOP16	Threshold-free driver (inverted output, open-collector)	6		20	10	1 M	4 to 18	20
TD62603PG/FG	DIP16/SOP16	Threshold-free driver (non-inverted output)	6		20	10	1 M	4 to 18	20
TD62604PG/FG	DIP16/SOP16	Threshold-free driver (non-inverted output, open-collector)	6		20	10	1 M	4 to 18	20
TD62703PG/FG	DIP14/SOP14	High breakdown voltage, source driver	6		60	-50	2.7 k	5	60
TD62706PG/FG	DIP16/SOP16	High breakdown voltage, source driver	6		60	-50	10 k	5	60
TD62708NG	DIP24N	Darlington source driver (with Enable pin)	8		40	-1800	NA	5	7
TD62781APG/AFG	DIP18	Darlington source driver (with pull-down resistor)	8		60	-50	10 k	5	60
TD62782APG/AFG	SOP18	Darlington source driver (with pull-down resistor)	8		35	-50	20 k	6 to 15	60
TD62783APG/AFG/AFNG	DIP18/SOP18 SSOP18	Darlington source driver	8	○	50	-500	10 k	5	50
TD62784APG/AFG/AFNG	DIP18/SOP18 SSOP18	Darlington source driver	8	○	50	-500	10 k	6 to 15	50
TD62785PG/FG	DIP18/SOP18	Darlington source driver	8		7	-500	5.6-k pull-up	5	7
TD62786APG/AFG	DIP18/SOP18	Darlington source driver	8	○	50	-500	14 k	5	50
TD62787AFG	SOP18	Darlington source driver	8	○	50	-500	14 k + D.	5	50

• Contact the Toshiba sales representative for information about RoHS compliance before you purchase any components.

(DMOS Arrays)

Part Number	Package	Device Type	Description	Power Supply Voltage (V)
TB62004FG/PG	SOP20/DIP20	8-bit DMOS driver	8-bit DMOS driver with non-inverter gate, 35 V / 200 mA	7

• Contact the Toshiba sales representative for information about RoHS compliance before you purchase any components.

(Multi-Chip Transistor Arrays)

Part Number	Package	Device Type	Characteristics		Power Supply Voltage (V)
			Output Breakdown Voltage (V)	Output Current (A)	
TD62M4700FG	SSOP16	2-ch low-saturation push-pull driver	10	± 2.0	10
TD62M3601FG	SSOP10	3-ch low-saturation source driver	-30	-1.5	-30
TD62M3701FG	SSOP16	3-ch low-saturation push-pull driver	10	± 2.0	10
TD62M3702FG	SSOP16	3-ch low-saturation push-pull driver	15	± 2.0	15
TD62M4501FG	SSOP16	4-ch low-saturation sink driver	20	2.0	20
TD62M4600FG	SSOP16	4-ch low-saturation source driver	-10	-2.0	-10
TD62M4601FG	SSOP16	4-ch low-saturation source driver	-20	-2.0	-20
TD62M8600FG	HSOP16	8-ch low-saturation source driver	-10	-2.0	-10
TD62M8603FG	HSOP16	8-ch low-saturation source driver	-30	-1.5	-30

• Contact the Toshiba sales representative for information about RoHS compliance before you purchase any components.

CCD Clock Driver ICs

Part Number	Package	Applications	Description	Power Supply Voltage (V)
TB62801FG ☆	HSOP16	CCD linear image sensor	Linear CCD clock driver	7
TB62802FG ☆	HSOP16	CCD linear image sensor	Linear CCD clock driver (reduced EMI noise)	7

☆: Dry-packed

- Contact the Toshiba sales representative for information about RoHS compliance before you purchase any components.

Thermal Head Driver ICs

Part Number	Package	Applications	Description	Power Supply Voltage (V)
TD62C852PG	DIP20	8-bit solenoid driver	8-bit shift register/latch driver (50 V / 500 mA)	7
TD62C854AFG	SSOP24	8-bit LED driver	Power-On-reset, 8-bit shift register/latch driver (50 V / 500 mA)	7
TB62600FG	QFP100	64-bit TPH driver	8-bit parallel input, 8-stage (1-bit input, 64-stage) shift register/latch driver (30 V / 130 mA)	7

- Contact the Toshiba sales representative for information about RoHS compliance before you purchase any components.

Vending Machine Driver ICs

Part Number	Package	Applications	Description	Power Supply Voltage (V)	
TD62650FG	SSOP30 (1.0 mm)	Vending machines	Power supply monitor threshold: 92% of 5 V, On-chip resistor for reset timer	7	
TD62651FG			5-V power supply and power supply monitor and 24-V communications interface IC	Power supply monitor threshold: 85% of 5 V, Requires external resistor for reset timer	7
TD62652FG			Power supply monitor threshold: 92% of 5 V, Requires external resistor for reset timer	7	

- Contact the Toshiba sales representative for information about RoHS compliance before you purchase any components.

Other Driver ICs

Part Number	Package	Applications	Description	Power Supply Voltage (V)
TD62930FG	SSOP16 (1.0 mm)	IGBT gate driver for home appliances (inverters)	3-ch small-signal push-pull driver (30 V/±100 mA)	7

- Contact the Toshiba sales representative for information about RoHS compliance before you purchase any components.

Motor Drivers

Brush Motor Driver ICs (Bridge Driver ICs)

Part Number	Package	Characteristics		Description	Power Supply Voltage (V)
		Absolute Maximum Ratings			
		I _O (A)	V _O (V)		
TA7267BP	HSIP7	3.0	25	I _{OUT} = 1.0 A (avg), 3.0 A (peak), internal diodes, 4 modes	V _{CC} = 6 to 18 V _S = 0 to 18
TA7279AP/P	HDIP14	3.0	AP: 25 P: 20	2 channels 4 modes, I _{OUT} = 1.0 A (avg), 3.0 A (peak), internal diodes, thermal shutdown	V _{CC} = 6 to 18 V _S = 0 to 16 (P) V _S = 0 to 18 (AP)
TA7288P	HSIP10	2.0	25	Sequential dual driver with V _{ref} , I _{OUT} = 1.0 A (avg), 2.0 A (peak), internal diodes, 4 modes, thermal shutdown, output pin protection, shoot-through current protection, input hysteresis	V _{CC} = 4.5 to 18 V _S = 0 to 18
TA8409SG	SIP9	1.0	25	4 modes, I _{OUT} = 0.4 A (avg), 1.0 A (peak), V _{CC} (max) = 25 V, internal diodes, thermal shutdown, standby function, input hysteresis	V _{CC} = 4.5 to 20 V _S = 0 to 20
TA8409FG	SSOP10	1.0	25		
TA7291P	HSIP10	2.0	25	4 modes, I _{OUT} = 1.0 A (avg), 2.0 A (peak), internal diodes, V _{ref} , V _{CC} (max) = 25 V, thermal shutdown, output pin protection, standby function, input hysteresis	V _{CC} = 4.5 to 20 V _S = 0 to 20
TA7291SG	SIP9	1.2	25	4 modes, I _{OUT} = 0.4 A (avg), 1.2 A (peak), internal diodes, V _{ref} , V _{CC} (max) = 25 V, thermal shutdown, output pin protection, standby function, input hysteresis	V _{CC} = 4.5 to 20 V _S = 0 to 20
TA7291FG	HSOP16	1.2	25	4 modes, I _{OUT} = 0.4 A (avg), 1.2 A (peak), internal diodes, V _{ref} , V _{CC} (max) = 25 V, thermal shutdown, output pin protection, standby function, input hysteresis	V _{CC} = 4.5 to 20 V _S = 0 to 20
TA8428K	HSIP7	3.0	30	4 modes, I _{OUT} = 1.5 A (avg), 3.0 A (peak), V _{CC} (max) = 30 V, internal diodes, thermal shutdown, overcurrent protection	7 to 27
TA8428FG	HSOP20	2.4	30	4 modes, I _{OUT} = 0.8 A (avg), 2.4 A (peak), V _{CC} (max) = 30 V, internal diodes, thermal shutdown, overcurrent protection	7 to 27
TA8429HQ	HZIP12	4.5	30	4 modes, I _{OUT} = 3.0 A (avg), 4.5 A (peak), V _{CC} (max) = 30 V, thermal shutdown, overcurrent protection, HZIP power package	V _{CC} = 7 to 27 V _S = 0 to 27
TA7733FG	SSOP16	0.5	18	Low voltage (V _{CC} (min) = 1.8 V), I _{OUT} = 0.5 A (peak), 4 modes, wide operating voltage range, can be used as interface driver, high efficiency	1.8 to 15
TA8401FG	SSOP16	0.5	18	Low voltage (V _{CC} (min) = 3.0 V), I _{OUT} = 0.5 A (peak), 4 modes, wide operating voltage range, can be used as interface driver, high efficiency	3.0 to 15
TA8440HQ	HZIP12	3.0	50	H 50-V bridge switch, I _{OUT} = 1.5 A (avg), 3.0 A (peak), phase-chopper pin, 4 modes, internal diodes, thermal shutdown, CMOS-compatible inputs	4.5 to 5.5
TA8496FLG	☆ QON24	0.020	8	Constant-current operation, I _{OUT} = 20 mA, low-noise high-gain amp, magnetic head read/write for cameras, detection and writing of magnetic recording signals	V _{CC} = 3.5 to 7 V _{BAT} = 1.8 to 7
TA84007PQ	HSIP10	2.0	30	4 modes, I _{OUT} = 1.0 A (avg), 2.0 A (peak), internal diodes, V _{ref} , V _{CC} (max) = 30 V, thermal shutdown, output pin protection, standby function, input hysteresis	4.5 to 27
TA84007SG	SIP9	1.2	30	4 modes, I _{OUT} = 0.4 A (avg), 1.2 A (peak), internal diodes, V _{ref} , V _{CC} (max) = 30 V, thermal shutdown, output pin protection, standby function, input hysteresis	4.5 to 27
TA84007FG	HSOP16	1.2	30	4 modes, I _{OUT} = 0.4 A (avg), 1.2 A (peak), internal diodes, V _{ref} , V _{CC} (max) = 30 V, thermal shutdown, output pin protection, standby function, input hysteresis	4.5 to 27
TB6549PG	DIP16	3.5	30	PWM bridge driver, I _{OUT} (peak) = 3.5 A, V _{CC} (max) = 30 V, 4 modes, PWM control, standby function, thermal shutdown, overcurrent protection	10 to 27
TB6549FG	HSOP20	3.5	30		
TB6549HQ	HZIP25	4.5	30	PWM bridge driver, I _{OUT} (peak) = 4.5 A, V _{CC} (max) = 30 V, 4 modes, PWM control, standby function, thermal shutdown, overcurrent protection	10 to 27
TB6559FG	HSOP16	2.5	50	PWM bridge driver, 50 V/2.5 A (peak), 4 modes, constant-current PWM control, standby function, thermal shutdown, overcurrent protection, constant-current PWM control	10 to 27
TB62300FG	☆ HSOP-36-0.65	8.0	40	PWM chopper, constant-current dual DC motor driver, 40 V/8.0 A (pulse peak), 4 modes, constant-current PWM control, standby function, thermal shutdown, overcurrent protection	V _{DD} = 4.5 to 5.5 V _M = 20 to 36
TB6552FLG	☆ QON24	1	15	2-ch PWM bridge driver, 15 V/1 A (peak), 4 modes, standby function, thermal shutdown, direct PWM control	V _{CC} = 2.7 to 5.5 V _M = 2.5 to 13.5
TB6552FNG	☆ SSOP16	1	15	2-ch PWM bridge driver, 15 V/1 A (peak), 4 modes, standby function, thermal shutdown, direct PWM control	V _{CC} = 2.7 to 5.5 V _M = 2.5 to 13.5
TB6592FLG	☆ QON24	0.8	6	2-ch PWM bridge driver, 6 V/0.8 A (peak), 4 modes, standby function, thermal shutdown, direct PWM control	V _{CC} = 2.7 to 5.5 V _M = 2.2 to 5.5
TB6555FLG	☆ QON36	0.8	15	4-ch PWM bridge driver, 15 V/0.8 A (peak), 4 modes, standby function, thermal shutdown, direct PWM control	V _{CC} = 2.7 to 5.5 V _M = 2.5 to 13.5
TB6595FLG	☆ QON36	0.8	6	4-ch PWM bridge driver, 6 V/0.8 A (peak), 4 modes, standby function, thermal shutdown, direct PWM control	V _{CC} = 2.7 to 5.5 V _M = 2.2 to 5.5
TB6591FLG	☆ QON48	0.8	6	7-ch PWM bridge driver (6-ch full-bridge driver and 1-ch constant-current bridge driver), 6.0 V/0.8 A (peak), 4 modes, output PWM control, standby function, thermal shutdown	V _{CC} = 2.7 to 5.5 V _M = 2.2 to 5.5
TB6557FLG	☆ QON36	0.8	15	6-ch PWM bridge driver, 15 V/0.8 A (peak), 4 modes, standby function, thermal shutdown, direct PWM control, serial interface decoder	V _{CC} = 2.7 to 5.5 V _M = 2.5 to 13.5
TB6607FLG	☆ QON36	0.8	6	5-ch PWM bridge driver, 6 V/0.8 A (peak), 4 modes, direct PWM control, standby function, thermal shutdown	3 to 5.5
TB6596FLG	☆ QON36	0.8	6	6-ch PWM bridge driver, 6 V/0.8 A (peak), 4 modes, direct PWM control, standby function, thermal shutdown	2.2 to 5.5

☆: Dry-packed

- Contact the Toshiba sales representative for information about RoHS compliance before you purchase any components.

Brush Motor Driver ICs (Bridge Driver ICs) (Continued)

Part Number	Package	Characteristics		Description	Power Supply Voltage (V)
		Absolute Maximum Ratings			
		I _o (A)	V _o (V)		
TB6558FLG	☆ QON24	0.8	15	2-ch PWM chopper, constant-current driver, 15 V/0.8 A (peak), 4 modes, constant-current PWM control, standby function, thermal shutdown	V _{CC} = 2.7 to 5.5 V _M = 2.5 to 13.5
TB6561NG	SDIP24	1.5	40	2-ch PWM bridge driver, 40 V/1.5 A (peak), 4 modes, V _{DD} -less, direct PWM control, standby function, thermal shutdown	10 to 36
TB6561FG	SSOP30	1.5	40		
TB6593FNG	* ☆ SSOP20	3.2	15	PWM bridge driver, 15 V/3.2 A (peak), 4 modes, PWM control, standby function, thermal shutdown	V _{CC} = 2.7 to 5.5 V _M = 2.5 to 13.5
TB6590FTG	* ☆ VQON16	0.5	6	2-ch PWM bridge driver, 6 V/0.5 A (peak), 4 modes, standby function, thermal shutdown	V _{CC} = 2.7 to 5.5 V _M = 2.2 to 5.5
TB6594FLG	* ☆ QON24	0.8	5.5	2-ch PWM bridge driver, 5.5 V/0.8 A (peak), 4 modes, DC-DC converter with a 5-V voltage booster, standby function, thermal shutdown	V _{CC} = 2.7 to 5 V _M = 2.2 to 5
TB6612FNG	* ☆ SSOP24	3.2	15	2-ch PWM bridge driver, 15 V/3.2 A (peak), 4 modes, PWM control, standby function, thermal shutdown	V _{CC} = 2.7 to 5.5 V _M = 4.5 to 13.5

☆: Dry-packed

*: New product

- Contact the Toshiba sales representative for information about RoHS compliance before you purchase any components.

Brushless Motor Driver ICs (3-phase Controllers/Drivers)

Part Number	Package	Characteristics		Description	Power Supply Voltage (V)
		Absolute Maximum Ratings			
		Io (A)	Vo (V)		
TA7712PG	DIP20	0.025	8	General-purpose motor driver; requires external transistors, 3-phase full-wave driver, rotation signal output, brake function	4.75 to 5.25
TA7712FG	SSOP24	0.025	8		
TB6539NG	SDIP24	0.02	18	3-phase full-wave sine-wave PWM motor controller	V _{CC} = 10 to 18 V _M = 4.5 to 18
TB6539FG	☆ SSOP30	0.02	18		
TB6551FG	☆ SSOP24	0.002	12	3-phase full-wave sine-wave PWM motor controller	6 to 10
TB6556FG	☆ SSOP30	0.002	12	3-phase full-wave sine-wave PWM motor controller, automatic lead angle control	6 to 10
TB6581HG	HZIP25	2.0	500	3-phase full-wave sine-wave PWM motor driver, sine-wave controller and TPD4103AK integrated in one package	V _{CC7} = 6 to 10 V _{CC15} = 13.5 to 16.5 V _B = 50 to 400
TB6585FG	* HSOP36	1.8	45	3-phase full-wave sine-wave PWM motor driver	V _M = 4.5 to 42
TA7259P	HDIP14	1.2	26	3-phase full-wave driver, current-controlled	7 to 18
TA7259FG	HSOP20	1.2	26		
TA7745PG	DIP16	1.0	18	3-phase full/half-wave driver, voltage-controlled, suitable for low-voltage applications	V _{CC} = 4.0 to 15 V _S = 2 to 15
TA7745FG	SSOP16	1.0	18		
TA8470AFG	HSOP20	1.2	18	Low-noise drive, internal FG amp	7 to 17
TA8483CP	HDIP14	2.0	35	3-phase full-wave driver, allows PWM sensorless drive with TB6520P	20 to 30
TA84005FG	☆ SSOP30	1.0	25	3-phase full-wave driver, allows PWM sensorless drive with TB6548F	V _{CC} = 4.5 to 5.5 V _M = 10 to 22
TA84006FG	☆ SSOP30	1.0	25	3-phase full-wave driver	V _{CC} = 4.5 to 5.5 V _M = 10 to 22
TA8490AF	SSOP30	1.2	16	CD-ROM spindle motor driver	V _{CC} = 4.5 to 5.5 V _M = 3 to 14
TA8492P/PG	DIP16	1.5	20	3-phase full-wave driver, voltage-controlled	V _{CC} = 7 to 18 V _S = 0 to 18
TA8493F	SSOP30	1.2	16	CD-ROM spindle motor driver, direct PWM control	V _{CC} = 4.5 to 5.5 V _M = 10 to 14
TA8493AF	SSOP30	1.2	16		
TA8493BF	SSOP30	1.2	16		
TA8499F	SSOP30	1.2	16	CD-ROM spindle motor driver, direct PWM control	V _{CC} = 4.5 to 5.5 V _M = 8 to 14
TB6520PG	DIP16	0.0002	7	PWM sensorless motor controller, V _{CC} = 5 V, dedicated companion to TA8483CP	4.5 to 5.5
TB6537PG/FG	DIP18/SSOP24	0.02	5.5	PWM sensorless motor controller, V _{CC} = 5 V, requires external transistor	4.5 to 5.5
TB6548FG	SSOP24	0.02	5.5	PWM sensorless motor controller, V _{CC} = 5 V, dedicated companion to TA84005F	4.5 to 5.5
TB6575FNG	☆ SSOP24 (0.65 mm)	0.02	5.5	PWM sensorless motor controller, analog speed control input, startup settings	4.5 to 5.5
TB6586FG/AFG/BFG	* ☆ SSOP24	0.003	18	3-phase full-wave controller with 150° large-angle excitation	V _{CC} = 6.5 to 16.5 V _M = 4.5 to 16.5
TB6571FG	☆ QFP52	0.02	30	3-phase full-wave sine-wave PWM motor controller, Speed control	V _{CC} = 10 to 28
TB6588FG	* ☆ HSOP36	2.5	50	PWM sensorless motor driver, analog speed control input, startup settings	V _M = 7 to 42

☆: Dry-packed

*: New product

- Contact the Toshiba sales representative for information about RoHS compliance before you purchase any components.

(2-phase Fan Driver Controllers)

Part Number	Package	Characteristics		Description	Power Supply Voltage (V)
		Absolute Maximum Ratings			
		Io (A)	Vo (V)		
TA8473FG	SSOP16	1.2	13.8	Fan motor driver, variable speed, radio noise reduction pin	6 to 13.8
TA8473FNG	SSOP16 (0.65 mm)	1.2	13.8		

- Contact the Toshiba sales representative for information about RoHS compliance before you purchase any components.

Stepping Motor Driver ICs (Bipolar)

Part Number	Package	Characteristics		Description	Power Supply Voltage (V)
		Absolute Maximum Ratings			
		I _o (A)	V _o (V)		
TA8435HQ	HZIP25	1.5	40	Pseudo-sine-wave drive (PWM chopper), reset and monitor pins, micro-step decoder, clock input	V _{CC} = 4.5 to 5.5 V _M = 21.6 to 26.4
TB62201AFG	☆ HSOP-36-0.65	1.5	40	Pseudo-sine-wave drive (PWM chopper), dual stepping motor driver	V _{DD} = 4.5 to 5.5 V _M = 20 to 3
TB62202AFG	☆ HSOP-36-0.65	1.0	40	Pseudo-sine-wave drive (PWM chopper), dual stepping motor driver	V _{DD} = 4.5 to 5.5
TB62205FG	☆ HSOP-36-0.65	0.7	30	2-ch step-down DC/DC converter, pseudo-sine-wave drive (PWM chopper), V _{DD} -less	V _M = 11 to 28
TB62206FG	☆ HSOP20-1.00	1.8	40	PWM chopper, phase input, 2-phase/1-2-phase excitation	V _{DD} = 4.5 to 5.5 V _M = 13 to 36
TB62208FTG	☆ QFN48-0.50	1.8	40	PWM chopper, phase input, 2-phase/1-2-phase excitation, V _{DD} -less	V _M = 10 to 35
TB62209FG	☆ HSOP-36-0.65	1.8	40	Pseudo-sine-wave drive (PWM chopper), micro-step decoder, clock input	V _{DD} = 4.5 to 5.5 V _M = 13 to 36
TB62217AFG	☆ THQFP64-0.50	2.5	50	Pseudo-sine-wave drive (PWM chopper), selectable dual stepping motor driver, synchronous 3-ch step-down DC/DC converter, V _{DD} -less	V _M = 7 to 40
TB62237BFG	☆ THQFP64-0.50	2.5	40	Pseudo-sine-wave drive (PWM chopper), selectable dual stepping motor driver, asynchronous 3-ch step-down DC/DC converter, V _{DD} -less	V _M = 7 to 36
TB62212FTAG	** ☆ QFN48-0.50	1.0	40	PWM chopper selectable stepping motor driver, V _{DD} -less (4-ch H switches)	V _M = 10 to 38
TB62230FTG	☆ VQON44-0.40	1.0	40	PWM chopper dual stepping motor driver, V _{DD} -less	V _M = 11 to 38
TB62214FG/FTG	** HSOP28 /QFN48-0.50	1.8	40	Pseudo-sine-wave drive (PWM chopper), clock input (2-phase/1-2-phase/W1-2-phase excitation), V _{DD} -less	V _M = 10 to 35
TB62218FG/FTG	** HSOP28 /QFN48-0.50	1.8	40	Pseudo-sine-wave drive (PWM chopper), phase input (2-phase/1-2-phase/W1-2-phase excitation), V _{DD} -less	V _M = 10 to 35
TB62207BFG	☆ HSOP36-0.65	2.5	37	Pseudo-sine-wave drive (PWM chopper), selectable dual stepping motor driver, synchronous 2-ch step-down DC/DC converter, V _{DD} -less	V _M = 15 to 32
TB6504FG	SSOP24	0.15	18	Pseudo-sine-wave drive (PWM chopper), reset and monitor pins, micro-step decoder, clock input	V _{CC} = 4.5 to 5.5 V _M = 5.5 to 8.0
TB6512AFG	SSOP24	0.12	12	Pseudo-sine-wave drive (PWM chopper), reset and monitor pins, micro-step decoder, clock input	V _{CC} = 2.7 to 5.5 V _M = 4.0 to 10.0
TB6526AFG	SSOP24	0.12	10	Pseudo-sine-wave drive (PWM chopper), reset and monitor pins, micro-step decoder, requires external PNP transistors	V _{CC} = 2.7 to 5.5 V _M = 3.5 to 8.0
TB6608FNG	* SSOP20	0.8	15	Pseudo-sine-wave drive (PWM chopper), reset and monitor pins, micro-step decoder, clock input	V _{CC} = 2.7 to 5.5 V _M = 2.5 to 13.5
TA84002FG	HSOP20	1.0	35	Bipolar PWM chopper, phase input, 2-phase/1-2-phase excitation	V _{CC} = 4.5 to 5.5 V _M = 10 to 30
TA7289P	HDIP14	1.5	30	Bipolar PWM chopper, 4-bit DA converter	6 to 27
TA7289FG	HSOP20	0.7	30		
TA7774PG	DIP16	0.4	17		
TA7774FG	HSOP16	0.4	17	Bipolar drive, selectable power supply voltages	V _{CC} = 4.5 to 5.5 V _{S1} = 10.8 to 13.2
TB6598FNG	SSOP16	0.8	15	PWM chopper, phase input, 2-phase/1-2-phase excitation	V _{CC} = 2.7 to 5.5 V _M = 2.5 to 13.5
TB6562ANG/AFG	SDIP24/SSOP30	1.5	40	PWM chopper, phase input, 2-phase/1-2-phase/W1-2-phase excitation, V _{DD} (5 V) regulator for internal logic	10 to 34
TB6560AHQ	* HZIP25	3.5	40	Pseudo-sine-wave drive (PWM chopper), reset and monitor pins, micro-step decoder, clock input, 2-phase/1-2-phase/2W1-2-phase/4W1-2-phase excitation	V _{CC} = 4.5 to 5.5 V _M = 4.5 to 34.0
TB6560AFG	* THQFP64	2.5	40		
TB6613FTG	☆ VQON44	0.8	6	Pseudo-sine-wave drive (PWM chopper), 6-bit microstepping decoder, selectable quad stepping motor driver	V _{CC} = 2.7 to 5.5 V _M = 2.2 to 6.0

☆: Dry-packed

• Contact the Toshiba sales representative for information about RoHS compliance before you purchase any components.

*: New product

** : Under development

(Unipolar)

Part Number	Package	Characteristics		Description	Power Supply Voltage (V)
		Absolute Maximum Ratings			
		I _o (A)	V _o (V)		
TD62064APG/AFG	DIP16/HSOP16	1.5	50	Quad NPN darlington transistor array, internal clamp diodes, active-High	—
TD62064BP1G/BFG	DIP16/HSOP16	1.5	80	Quad NPN darlington transistor array, internal clamp diodes, active-High	—
TD62107PG/FG	DIP16/HSOP16	0.75	45/35	Quad NPN darlington transistor array, internal clamp diodes and Enable pin	17
TD62164APG/AFG	DIP16/HSOP16	0.7	50	Quad NPN single transistor array, internal clamp diodes, active-High	17
TD62164BPG/BFG	DIP16/HSOP16	0.7	80	Quad NPN single transistor array, internal clamp diodes, active-High	17
TD62308APG/AFG	DIP16/HSOP16	1.5	50	Quad NPN darlington transistor array, internal clamp diodes, active-Low	10
TD62308BP1G/BFG	DIP16/HSOP16	1.5	80	Quad NPN darlington transistor array, internal clamp diodes, active-Low	10
TD62318APG/AFG	DIP16/HSOP16	0.7	50	Quad NPN single transistor array, internal clamp diodes, active-Low	17
TD62318BPG/BFG	DIP16/HSOP16	0.7	80	Quad NPN single transistor array, internal clamp diodes, active-Low	17
TB6615PG	* DIP16	0.4	28	1-phase, 2-phase and 1-2-phase excitation for 3- and 4-phase motors, unipolar, I _{OUT} = 0.4 A	2.7 to 5.5

• Contact the Toshiba sales representative for information about RoHS compliance before you purchase any components.

*: New product

(5-phase Controllers)

Part Number	Package	Characteristics		Description	Power Supply Voltage (V)
		Absolute Maximum Ratings			
		Io (A)	Vo (V)		
TB6528P	DIP24	0.03	20	5-phase universal controller	4 to 16

- Contact the Toshiba sales representative for information about RoHS compliance before you purchase any components.

Power Supply ICs

Point Regulators (LDO Regulators)

Point regulators are so small they can be locally assigned to individual circuit blocks, making them suitable for applications requiring low dropout.

These devices incorporate an ON/OFF control function, which facilitates power management.

< Features >

- Small package
- Low current consumption (CMOS Type)
- Low saturation voltage
- Low noise
- High ripple rejection
- ON/OFF control function
- Overcurrent protection
- Capable of using a ceramic capacitor
- Overtemperature protection (Bipolar Type)

< Low-Dropout Voltage Regulator Series >

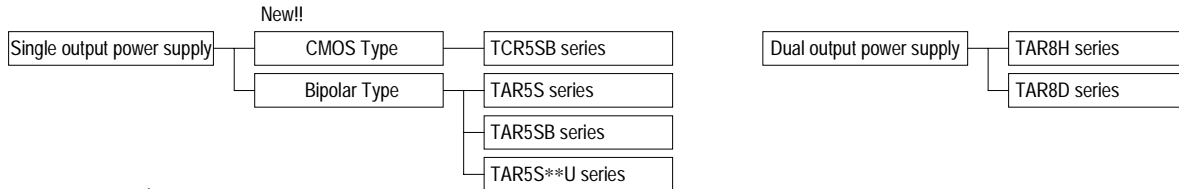

(Single Output CMOS Type)

Output Voltage (V)	Part Number	Ratings	
	Output Current (mA)	Power Dissipation (Note) (mW)	
1.5	TCR5SB15 *	200	380
1.6	TCR5SB16 *		
1.7	TCR5SB17 *		
1.8	TCR5SB18 *		
1.9	TCR5SB19 *		
2.0	TCR5SB20 *		
2.1	TCR5SB21 ◇		
2.2	TCR5SB22 ◇		
2.3	TCR5SB23 *		
2.4	TCR5SB24 ◇		
2.5	TCR5SB25 *		
2.6	TCR5SB26 ◇		
2.7	TCR5SB27 *		
2.8	TCR5SB28 *		
2.9	TCR5SB29 *		
3.0	TCR5SB30 *		
3.1	TCR5SB31 *		
3.2	TCR5SB32 ◇		
3.3	TCR5SB33 *		
3.4	TCR5SB34 ◇		
3.5	TCR5SB35 *		
3.6	TCR5SB36 ◇		
3.7	TCR5SB37 ◇		
3.8	TCR5SB38 ◇		
3.9	TCR5SB39 ◇		
4.0	TCR5SB40 *		
4.1	TCR5SB41 ◇		
4.2	TCR5SB42 ◇		
4.3	TCR5SB43 ◇		
4.4	TCR5SB44 ◇		
4.5	TCR5SB45 *		
4.6	TCR5SB46 ◇		
4.7	TCR5SB47 *		
4.8	TCR5SB48 *		
4.9	TCR5SB49 *		
5.0	TCR5SB50 *		
Pin Configuration			

◇: Please contact your nearest Toshiba sales representative.

*: New product

Note: A result of an evaluation on a glass-epoxy board (30 mm x 30 mm), Ta = 25°C

Please ask your local retailer about the devices with other output voltages.

- Contact the Toshiba sales representative for information about RoHS compliance before you purchase any components.

(Single Output Bipolar Type)

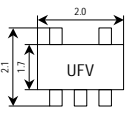
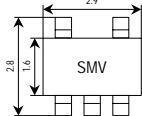
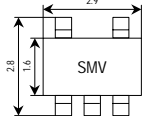
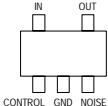
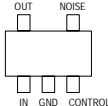
Output Voltage (V)	Part Number			Ratings	
	 (mm)	 (mm)	 (mm)	Output Current (mA)	Power Dissipation (Note) (mW)
1.5	TAR5S15U	TAR5S15	TAR5SB15	200	450 (UFV)
1.6	TAR5S16U	TAR5S16	TAR5SB16		
1.7	TAR5S17U	TAR5S17	TAR5SB17		
1.8	TAR5S18U	TAR5S18	TAR5SB18		
1.9	TAR5S19U	TAR5S19	TAR5SB19		
2.0	TAR5S20U	TAR5S20	TAR5SB20		
2.1	TAR5S21U	TAR5S21	TAR5SB21		
2.2	TAR5S22U	TAR5S22	TAR5SB22		
2.3	TAR5S23U	TAR5S23	TAR5SB23		
2.4	TAR5S24U	TAR5S24	TAR5SB24		
2.5	TAR5S25U	TAR5S25	TAR5SB25		
2.6	TAR5S26U	TAR5S26	TAR5SB26		
2.7	TAR5S27U	TAR5S27	TAR5SB27		
2.8	TAR5S28U	TAR5S28	TAR5SB28		
2.9	TAR5S29U	TAR5S29	TAR5SB29		
3.0	TAR5S30U	TAR5S30	TAR5SB30		
3.1	TAR5S31U	TAR5S31	TAR5SB31		
3.2	TAR5S32U	TAR5S32	TAR5SB32		
3.3	TAR5S33U	TAR5S33	TAR5SB33		
3.4	TAR5S34U	TAR5S34	TAR5SB34		
3.5	TAR5S35U	TAR5S35	TAR5SB35		
3.6	TAR5S36U	TAR5S36	TAR5SB36		
3.7	TAR5S37U	TAR5S37	TAR5SB37		
3.8	TAR5S38U	TAR5S38	TAR5SB38		
3.9	TAR5S39U	TAR5S39	TAR5SB39		
4.0	TAR5S40U	TAR5S40	TAR5SB40		
4.1	TAR5S41U	TAR5S41	TAR5SB41		
4.2	TAR5S42U	TAR5S42	TAR5SB42		
4.3	TAR5S43U	TAR5S43	TAR5SB43		
4.4	TAR5S44U	TAR5S44	TAR5SB44		
4.5	TAR5S45U	TAR5S45	TAR5SB45		
4.6	TAR5S46U	TAR5S46	TAR5SB46		
4.7	TAR5S47U	TAR5S47	TAR5SB47		
4.8	TAR5S48U	TAR5S48	TAR5SB48		
4.9	TAR5S49U	TAR5S49	TAR5SB49		
5.0	TAR5S50U	TAR5S50	TAR5SB50		380 (SMV)
Pin Configuration					

Note: A result of an evaluation on a glass-epoxy board (30 mm x 30 mm), Ta = 25°C

Please ask your local retailer about the devices with other output voltages.

- Contact the Toshiba sales representative for information about RoHS compliance before you purchase any components.

(Dual Output Bipolar Type)

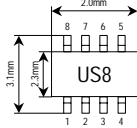
Part Number		Package	Description	Characteristics				
				Output Voltage (V)	Output Current (mA)	Power Dissipation (Note)	Internal Connections	
TAR8H01K	Ach		Synchronous switch type	2.8	100	400	1. CONTROL 2. Noise(A) 3. Noise(B) 4. GND 5. Vout(B) 6. Vin(B) 7. Vin(A) 8. Vout(A)	
	Bch			3.0	150			
TAR8H02K	Ach			2.8	100			
	Bch			2.8	150			
TAR8H03K	Ach			2.5	100			
	Bch			2.8	150			
TAR8H04K	Ach			2.5	100			
	Bch			3.0	150			
TAR8H05K	Ach			1.8	100			
	Bch			2.8	150			
TAR8H06K	Ach			1.5	100			
	Bch			2.5	150			
TAR8D01K	Ach		Independent control type	2.5	100		400	1. Noise(A) 2. Noise(B) 3. CONTROL(A) 4. GND 5. CONTROL(B) 6. Vout(B) 7. Vin 8. Vout(A)
	Bch			2.8				
TAR8D02K	Ach			2.0				
	Bch			2.8				
TAR8D03K	Ach			2.8				
	Bch			3.0				
TAR8D04K	Ach			1.5				
	Bch			1.5				
TAR8D05K	Ach			2.8				
	Bch			2.8				
TAR8D06K	Ach			2.9				
	Bch			2.9				
TAR8D07K	Ach	3.0						
	Bch	3.0						
TAR8D08K	Ach	2.8						
	Bch	2.85						

Note: A result of an evaluation on a glass-epoxy board (30 mm x 30 mm), Ta = 25°C

Dual-output LDO regulators allow for semi-customization of individual output voltage, which can be 1.5 V to 5.0 V at 0.1-V intervals.

- Contact the Toshiba sales representative for information about RoHS compliance before you purchase any components.

Series Regulators

Part Number	Package	Polarity	Features	Electrical Characteristics							Equivalent	
				Output Voltage Typ. (V)	Output Current Max (mA)	Input Voltage Max (V)	Dropout Voltage Typ. (V)	Bias Current Typ. (mA)	Output Voltage Tolerance (%)	Power Dissipation (W)		
TA7805F TA78057F TA7806F TA7807F TA7808F TA7809F TA7810F TA7812F TA7815F TA7818F TA7820F TA7824F	PW-Mold	Positive-voltage output	High-current output Note: Surface-mount PW-Mold package	5	1000	35	2 (I _o = 1000 mA)	4.2	±4 (T _J = 25°C)	1 (T _a = 25°C) 10 (T _c = 25°C)	78XX	
5.7												
6												
7												
8												
9												
10												
12												
15												
18												
20												
24												
							40		4.4			
									4.5			
									4.6			
									(I _o = 5 mA)			
TA7805SB TA78057SB TA7806SB TA7807SB TA7808SB TA7809SB TA7810SB TA7812SB TA7815SB TA7818SB TA7820SB TA7824SB	TPL			High-current output Note: Ammo packaging for automated pick-and-place assembly	5	1000	35	2 (I _o = 1000 mA)	4.2	±4 (T _J = 25°C)	1.8 (T _a = 25°C)	78XX
5.7												
6												
7												
8												
9												
10												
12												
15												
18												
20												
24												
						40		4.4				
								4.5				
								4.6				
								(I _o = 5 mA)				
TA78033AF TA7804AF TA7805AF TA7807AF TA7808AF TA7809AF	New PW-Mold		High-current output Note: Surface-mount New PW-Mold package	3.3	1000	20	2 (I _o = 1000 mA)	3 (I _o = 5 mA)	±4 (T _J = 25°C)	1 (T _a = 25°C) 10 (T _c = 25°C)	78XX	
4												
5												
7												
8												
9												
TA78M05F TA78M06F TA78M08F TA78M09F TA78M10F TA78M12F TA78M15F TA78M18F TA78M20F TA78M24F	PW-Mold		Medium-current output Note: Surface-mount PW-Mold package	5	500	35	1.7 (I _o = 350 mA)	4.5	±4 (T _J = 25°C)	1 (T _a = 25°C) 10 (T _c = 25°C)	78MXX	
6												
8												
9												
10												
12												
15												
18												
20												
24												
						40		4.7				
								4.8				
								4.9				
								5.0				
								(I _o = 350 mA)				
TA78M05SB TA78M06SB TA78M08SB TA78M09SB TA78M10SB TA78M12SB TA78M15SB TA78M18SB TA78M20SB TA78M24SB	TPL		Medium-current output Note: Ammo packaging for automated pick-and-place assembly	5	500	35	1.7 (I _o = 350 mA)	4.5	±4 (T _J = 25°C)	1.8 (T _a = 25°C)	78MXX	
6												
8												
9												
10												
12												
15												
18												
20												
24												
						40		4.7				
								4.8				
								4.9				
								5.0				
								(I _o = 350 mA)				
TA78L005AP TA78L006AP TA78L007AP TA78L075AP TA78L008AP TA78L009AP TA78L010AP TA78L012AP TA78L132AP TA78L015AP TA78L018AP TA78L020AP TA78L024AP	LSTM		Low-current output Note: Optionally available in ammo packaging for automated pick-and-place assembly	5	150	35	1.7 (I _o = 150 mA)	3.1	±4 (T _J = 25°C)	0.8 (T _a = 25°C)	78LXX	
6												
7												
7.5												
8												
9												
10												
12												
13.2												
15												
18												
20												
24												
						40		3.2				
								3.3				
								3.5				
								(I _o = 40 mA)				

- The products shown in bold are also manufactured in offshore fabs.
- Contact the Toshiba sales representative for information about RoHS compliance before you purchase any components.

Series Regulators (Continued)

Part Number	Package	Polarity	Features	Electrical Characteristics							Equivalent			
				Output Voltage Typ. (V)	Output Current Max (mA)	Input Voltage Max (V)	Dropout Voltage Typ. (V)	Bias Current Typ. (mA)	Output Voltage Tolerance (%)	Power Dissipation (W)				
TA78L05F TA78L06F TA78L07F TA78L08F TA78L09F TA78L10F TA78L12F TA78L15F TA78L18F TA78L20F TA78L24F	PW-Mini (SOT-89)	Positive-voltage output	Low-current output Note: Surface-mount PW-Mini (SOT-89) package	5	150	35	1.7 (I _o = 150 mA)	3.1	±5 (T _J = 25°C)	0.5 (T _a = 25°C)	78LXX			
6	40			3.2										
7				3.3										
8				3.5 (I _o = 40 mA)										
9														
10														
12														
15														
18														
20														
24														
TA78L05PF TA78L06PF TA78L07PF TA78L08PF TA78L09PF TA78L10PF TA78L12PF TA78L15PF	PS-8	Positive-voltage output	Low-current output Note: Small, thin surface-mount PS-8 package	5	150	35	2 (I _o = 150 mA)	3.1	±4 (T _J = 25°C)	1.3 (T _a = 25°C) Mounted on a glass-epoxy board	78LXX			
6				3.2										
7				3.3 (I _o = 40 mA)										
8														
9														
10														
15														
TA78L05S TA78L07S TA78L08S TA78L09S TA78L10S TA78L12S TA78L15S	TO-92	Positive-voltage output	Low-current output Note: Ammo packaging for automated pick-and-place assembly	5	100	35	1.7 (I _o = 100 mA)	3.1	±4 (T _J = 25°C)	0.6 (T _a = 25°C)	78LXX			
7				3.2										
8				3.3 (I _o = 40 mA)										
9														
10														
12														
15														
TA48015BF TA48018BF TA48025BF TA48033BF TA4805BF TA4808BF TA4809BF	New PW-Mold	Positive-voltage output (low dropout)	High-current output Low dropout Note: Surface-mount New PW-Mold package	1.5	1000	16	0.95	0.85	±3 (T _J = 25°C)	1 (T _a = 25°C) 10 (T _c = 25°C)				
1.8	0.41													
2.5														
3.3	0.32 (I _o = 500 mA)													
5	0.90 (I _o = 0 A)													
8														
9														
TA48M025F TA48M03F TA48M033F TA48M0345F TA48M04F TA48M05F	PW-Mold	Positive-voltage output (low dropout)	Medium-current output Low dropout Note: Surface-mount PW-Mold package	2.5	500	29	0.35 (I _o = 500 mA)	0.8	±4 (T _J = 25°C)	1 (T _a = 25°C) 10 (T _c = 25°C)				
3	0.9													
3.3	1.0 (I _o = 0 A)													
3.45														
4														
5														
TA48L018F TA48L02F TA48L025F TA48L03F TA48L033F TA48L05F	PW-Mini (SOT-89)	Positive-voltage output (low dropout)	Low-current output Low dropout Note: Surface-mount PW-Mini (SOT-89) package	1.8	150	16	0.32	0.4 (I _o = 0 A)	±3 (T _J = 25°C)	0.5 (T _a = 25°C)				
2	0.30													
2.5														
3	0.27 (I _o = 100 mA)													
3.3														
5														
TA58L05F TA58L06F TA58L08F TA58L09F TA58L10F TA58L12F TA58L15F	New PW-Mold	Positive-voltage output (low dropout)	Medium-current output Low dropout Note: Surface-mount New PW-Mold package	5	250	29 (60 V load dump)	0.22 (I _o = 200 mA)	0.45	±3 (T _J = 25°C)	1 (T _a = 25°C) 10 (T _c = 25°C)				
6	0.50													
8	0.55													
9	0.60													
10	0.60													
12	0.65 (I _o = 0 A)													
15	0.75													
TA58L05S TA58L06S TA58L08S TA58L09S TA58L10S TA58L12S TA58L15S	TO-220NIS	Positive-voltage output (low dropout)	Medium-current output Low dropout Isolation package	5	250	29 (60 V load dump)	0.22 (I _o = 200 mA)	0.45	±3 (T _J = 25°C)	2 (T _a = 25°C) 20 (T _c = 25°C)				
6	0.50													
8	0.55													
9	0.60													
10	0.60													
12	0.65 (I _o = 0 A)													
15	0.75													

• Contact the Toshiba sales representative for information about RoHS compliance before you purchase any components.

Part Number	Package	Polarity	Features	Electrical Characteristics							Equivalent	
				Output Voltage Typ. (V)	Output Current Max (mA)	Input Voltage Max (V)	Dropout Voltage Typ. (V)	Bias Current Typ. (mA)	Output Voltage Tolerance (%)	Power Dissipation (W)		
TA58M05F TA58M06F TA58M08F TA58M09F TA58M10F TA58M12F TA58M15F	New PW-Mold	Positive-voltage output (low dropout)	Medium-current output Low dropout Note: Surface-mount New PW-Mold package	5 6 8 9 10 12 15	500	29 (60 V load dump)	0.42 (I _o = 500 mA)	0.5 0.6 0.7 (I _o = 0 A)	±3 (T _J = 25°C)	1 (T _a = 25°C) 10 (T _c = 10°C)		
TA58M05S TA58M06S TA58M08S TA58M09S TA58M10S TA58M12S TA58M15S	TO-220NIS		Medium-current output Low dropout Isolation package	5 6 8 9 10 12 15	500	29 (60 V load dump)	0.42 (I _o = 500 mA)	0.5 0.6 0.7 (I _o = 0 A)	±3 (T _J = 25°C)	2 (T _a = 25°C) 20 (T _c = 25°C)		
TA78DS05BP TA78DS05CP TA78DS06BP TA78DS08BP TA78DS09BP TA78DS10BP TA78DS12BP TA78DS15BP	LSTM		Low-current output Low dropout Note: Optionally available in ammo packaging for automated pick-and-place assembly	5 5 6 8 9 10 12 15	30	29 (60 V load dump)	0.2 (I _o = 10 mA)	0.6 0.7 0.8 1.0 (I _o = 0 A)	BP: ±5 CP: ±4 (T _J = 25°C)	0.8 (T _a = 25°C)		
TA78DS05F TA78DS05AF TA78DS06F TA78DS08F TA78DS09F TA78DS10F TA78DS12F TA78DS15F	PW-Mini (SOT-89)		Low-current output Low dropout Note: Surface-mount PW-Mini (SOT-89) package	5 5 6 8 9 10 12 15	30	29 (60 V load dump)	0.2 (I _o = 10 mA)	0.6 0.7 0.8 1.0 (I _o = 0 A)	F: ±5 AF: ±4 (T _J = 25°C)	0.5 (T _a = 25°C)		
TA79005SB TA79006SB TA79007SB TA79008SB TA79009SB TA79010SB TA79012SB TA79015SB TA79018SB TA79020SB TA79024SB	TPL		Negative-voltage output	High-current output Note: Ammo packaging for automated pick-and-place assembly	-5 -6 -7 -8 -9 -10 -12 -15 -18 -20 -24	1000	-35 -40	2 (I _o = -1000 mA)	4.3 4.4 4.5 4.6 (I _o = 500 mA)	±4 (T _J = 25°C)	1.8 (T _a = 25°C)	79XX
TA79L05F TA79L06F TA79L08F TA79L09F TA79L10F TA79L12F TA79L15F TA79L18F TA79L20F TA79L24F	PW-Mini (SOT-89)			Low-current output Note: Surface-mount PW-Mini (SOT-89) package	-5 -6 -8 -9 -10 -12 -15 -18 -20 -24	150	-35 -40	1.7 (I _o = -40 mA)	3.1 3.2 3.3 3.5 (I _o = 40 mA)	±4 (T _J = 25°C)	0.5 (T _a = 25°C)	79LXX
TA79L005P TA79L006P TA79L008P TA79L009P TA79L010P TA79L012P TA79L015P TA79L018P TA79L020P TA79L024P	LSTM			Low-current output Note: Optionally available in ammo packaging for automated pick-and-place assembly	-5 -6 -8 -9 -10 -12 -15 -18 -20 -24	150	-35 -40	1.7 (I _o = -40 mA)	3.1 3.2 3.3 3.5 (I _o = 40 mA)	±4 (T _J = 25°C)	0.8 (T _a = 25°C)	79LXX

• Contact the Toshiba sales representative for information about RoHS compliance before you purchase any components.

Shunt Regulators

Part Number	Package	Polarity	Features	Electrical Characteristics							Equivalent
				Reference Voltage Typ. (V)	Output Voltage Typ. (V)	Cathode Current Max (mA)	Cathode Voltage Max (V)	Minimum Cathode Current Max (mA)	Reference Voltage Tolerance (%)	Power Dissipation (W)	
TA76431F/FR	PW-Mini (SOT-89)	Positive-voltage output	Variable output voltage Note: Surface-mount PW-Mini (SOT-89) package	2.495	Variable 2.495 to 36	Sink 150	37	1.0	±2.2 (Ta = 25°C)	0.5 (Ta = 25°C)	431
TA76431S	LSTM		Variable output voltage Note: Optionally available in ammo packaging for automated pick-and-place assembly							0.8 (Ta = 25°C)	
TA76L431FT	UFV		Variable output voltage Note: Small, thin surface-mount UFV package	2.49	Variable 2.49 to 19	Sink 50	20	0.5	±1 (Ta = 25°C)	0.45 (Ta = 25°C) Mounted on a glass-epoxy board	431
TA76L431S	LSTM		Variable output voltage Note: Optionally available in ammo packaging for automated pick-and-place assembly							0.8 (Ta = 25°C)	
TA76L431FB	S-Mini		Variable output voltage Note: Small, thin surface-mount S-Mini package	2.495	Variable 2.495 to 19	Sink 50	20	0.5	±1 (Ta = 25°C)	0.2 (Ta = 25°C) Mounted on a glass-epoxy board	431
TA76432FT TA76432AFT	UFV		Variable output voltage Note: Small, thin surface-mount UFV package	1.26	Variable 1.26 to 19	Sink 20	20	0.5	±1.4 A: ±1.0 (Ta = 25°C)	0.45 (Ta = 25°C) Mounted on a glass-epoxy board	
TA76432FC	SMV		Variable output voltage Note: Surface-mount SMV package							0.38 (Ta = 25°C) Mounted on a glass-epoxy board	
TA76432F/FR TA76432AF/AFR	PW-Mini (SOT-89)		Variable output voltage Note: Surface-mount PW-Mini (SOT-89) package							0.5 (Ta = 25°C)	
TA76432S TA76432AS	LSTM		Variable output voltage Note: Optionally available in ammo packaging for automated pick-and-place assembly							0.8 (Ta = 25°C)	
TA76433FC	SMV		Cathode separation type Variable output voltage Note: Surface-mount SMV package	1.26	Variable 1.26 to 14	Sink 20	15	0.4	±1.4 (Ta = 25°C)	0.38 (Ta = 25°C) Mounted on a glass-epoxy board	

- The products shown in bold are also manufactured in offshore fabs.
- Contact the Toshiba sales representative for information about RoHS compliance before you purchase any components.

Multi-Functional Regulators

Part Number	Package	Polarity	Features	Electrical Characteristics							Equivalent
				Output Voltage Typ. (V)	Output Current Max (mA)	Input Voltage Max (V)	Dropout Voltage Typ. (V)	Bias Current Typ. (mA)	Output Voltage Tolerance (%)	Power Dissipation (W)	
TA48S015AF TA48S018AF TA48S025AF TA48S033AF TA48S05AF TA48S09AF	5-pin New PW-Mold	Positive-voltage output (low dropout)	High-current output Low dropout Built-in ON/OFF control function	1.5 1.8 2.5 3.3 5 9	1000	16	0.95 0.41 0.32 (I _o = 500 mA) 0.90 (I _o = 0 A)	0.85	±3 (T _J = 25°C)	1 (T _a = 25°C) 10 (T _c = 25°C)	
TA48S00AF	5-pin New PW-Mold		High-current output Low dropout Built-in ON/OFF control function Adjustable output voltage	1.5 to 9	1000	16	0.32 (I _o = 500 mA) V _o = 3.3 V	0.85 (I _o = 0 A)	±2.5 (V _{ref}) (T _J = 25°C)	1 (T _a = 25°C) 10 (T _c = 25°C)	
TA4800AF	5-pin New PW-Mold		High-current output Low dropout Adjustable output voltage	1.5 to 9	1000	16	0.32 (I _o = 500 mA) V _o = 3.3 V	0.85 (I _o = 0 A)	±2.5 (V _{ref}) (T _J = 25°C)	1 (T _a = 25°C) 10 (T _c = 25°C)	
TA48LS015F TA48LS018F TA48LS025F TA48LS033F TA48LS05F	PS-8		Low-current output Low dropout Built-in ON/OFF control function	1.5 1.8 2.5 3.3 5	300	14	0.7 0.5 0.4 0.3 (I _o = 300 mA)	1 (I _o = 0 A)	±2.5 (T _J = 25°C)	1.2 (T _a = 25°C) Mounted on a glass-epoxy board	
TA48LS00F	PS-8		Low-current output Low dropout Built-in ON/OFF control function Adjustable output voltage	1.5 to 5	300	14	0.3 (I _o = 300 mA) V _o = 3.3 V	1 (I _o = 0 A)	±2.3 (V _{ref}) (T _J = 25°C)	1.2 (T _a = 25°C) Mounted on a glass-epoxy board	
TA58MS033F TA58MS05F TA58MS06F TA58MS08F TA58MS09F TA58MS12F	5-pin New PW-Mold		Medium-current output Low dropout Built-in ON/OFF control function Bias current (OFF): 1 μA Max	3.3 5 6 8 9 12	500	29 (60 V load dump)	0.9 0.5 (I _o = 500 mA)	2.5 (I _o = 0 A)	±3 (T _J = 25°C)	1 (T _a = 25°C) 10 (T _c = 25°C)	
TA58MS00F	5-pin New PW-Mold		Medium-current output Low dropout Built-in ON/OFF control function Bias current (OFF): 1 μF Max Adjustable output voltage	2.5 to 24	500	29 (60 V load dump)	2.0 Max (I _o = 500 mA) V _o = 2.5 V	2.2 (I _o = 0 A) V _{IN} = 4.5 V	±3 (V _{ref}) (T _J = 25°C)	1 (T _a = 25°C) 10 (T _c = 25°C)	
TA58LT00F	5-pin New PW-Mold		Low-current output Low dropout Tracking accuracy Built-in ON/OFF control function	2.5 to 13.4	150	38 (60 V load dump)	0.6 Max (I _o = 100 mA)	0.8 Max (I _o = 0 A)	Tracking accuracy ±10 mV (T _J = 25°C)	1 (T _a = 25°C) 10 (T _c = 25°C)	
TA58ST00F	SOP-8		Low-current output Low dropout Tracking accuracy Built-in ON/OFF control function	2.5 to 13.4	50	38 (60 V load dump)	0.6 Max (I _o = 50 mA)	0.08 Max (I _o = 0 A)	Tracking accuracy ±10 mV (T _J = 25°C)	1.4 (T _a = 25°C) Mounted on a glass-epoxy board	

- Contact the Toshiba sales representative for information about RoHS compliance before you purchase any components.

DC-DC Converters (Monolithic ICs)

Part Number	Type	Input Supply Voltage (V)	Output Voltage Typ. (V)	Output Current Max (A)	Switching Frequency Typ. (kHz)	Package	Features
TB7100F	Buck	3 to 5.5	Variable	0.7	550	PS-8	Requires an external Schottky barrier diode from ground to the SW input.
TB7101F(T5L1.2,F)		2.7 to 5.5	1.2	1	1000		Synchronous rectification
TB7101F(T5L1.5,F)		2.7 to 5.5	1.5	1	1000		Synchronous rectification
TB7101F(T5L1.8,F)		2.8 to 5.5	1.8	1	1000		Synchronous rectification
TB7101F(T5L2.5,F)		3.5 to 5.5	2.5	1	1000		Synchronous rectification
TB7101F(T5L3.3,F)		4.3 to 5.5	3.3	1	1000		Synchronous rectification
TB7101AF(T5L1.2,F) *		2.7 to 5.5	1.2	1	1000		Synchronous rectification, TTL-compatible EN input
TB7101AF(T5L1.5,F) *		2.7 to 5.5	1.5	1	1000		Synchronous rectification, TTL-compatible EN input
TB7101AF(T5L1.8,F) *		2.8 to 5.5	1.8	1	1000		Synchronous rectification, TTL-compatible EN input
TB7101AF(T5L2.5,F) *		3.5 to 5.5	2.5	1	1000		Synchronous rectification, TTL-compatible EN input
TB7101AF(T5L3.3,F) *		4.3 to 5.5	3.3	1	1000		Synchronous rectification, TTL-compatible EN input
TB7102F		2.7 to 5.5	Variable	1	1000		Synchronous rectification
TB7102AF *		2.7 to 5.5	Variable	1	1000		Synchronous rectification, TTL-compatible EN input
TCV7100F *		2.7 to 5.5	Variable	2.5	800	Synchronous rectification	
TCV7101F *	2.7 to 5.5	Variable	3.8	600	SOP Advance	Requires external MOSFETs for synchronization. Can also be used as a chopper device.	

• Contact the Toshiba sales representative for information about RoHS compliance before you purchase any components.

*: New product

(Multi-Chip DC-DC Converters)

Part Number	Package	Characteristics		Features	Supply Voltage for Control Circuitry Typ. (V)	Remarks
		Absolute Maximum Ratings				
		V _{IN} - PGND Voltage (V)	I _{OUT} (A)			
TB7003FL ☆	56-pin QFN56	20	35	Operating frequency: 1 MHz Undervoltage lockout: disable input for the internal circuitry; thermal shutdown Low-side MOSFETs can be turned off.	5	
TB7004FL ☆		30	35	Operating frequency: 1 MHz Undervoltage lockout: disable input for the internal circuitry; thermal shutdown Boot switch: 5-V regulator; tri-state PWM input	12	DrMOS-compliant
TB7004AFL * ☆		30	35	Operating frequency: 1 MHz Undervoltage lockout: disable input for the internal circuitry; thermal shutdown Boot switch: 5-V regulator	12	3.3-V PWM input
TB7005FL * ☆		30	35	Operating frequency: 1 MHz Undervoltage lockout: disable input for the internal circuitry Low-side MOSFETs can be turned off. Boot switch	5	3.3-V PWM input High-current applications for notebook PCs
TB7007FL ** ☆		30	35	Operating frequency: 1 MHz Undervoltage lockout: disable input for the internal circuitry Boot switch	5	3.3-V PWM input Simplified functionality

Application Circuit Example

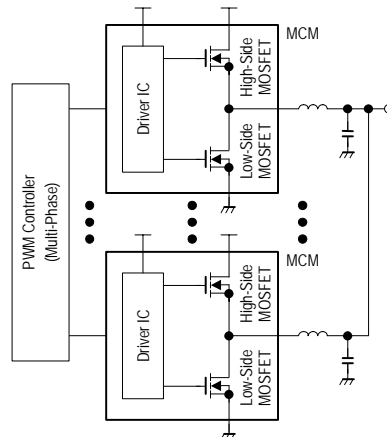

☆: Dry-packed

• Contact the Toshiba sales representative for information about RoHS compliance before you purchase any components.

*: New product

** : Under development

Other Power Supply ICs

Part Number	Package	Applications	Description	Power Supply Voltage (V)
TB62506FG * ☆	TQFP64	Power supply monitor and controller for notebook PCs	Power management IC for notebook PCs	—
TB62504FMG	SON8	System power supply for cell phone PAs	Step-down DC/DC converter (variable output) and switching MOSFETs, 300-mA output current capability	2.8 to 5.5

☆: Dry-packed

*: New product

- Contact the Toshiba sales representative for information about RoHS compliance before you purchase any components.

Small-Signal MMICs (Radio-Frequency Cell Packs)

Wideband Amp ICs

Part Number	Package	Applications	Functions	Electrical Characteristics	Supply Voltage (V)
TA4000F	SM6	BS tuners, communications equipment, VHF/UHF amps	Bipolar linear wideband amp	B/W = 1.3 GHz Gp = 15dB @f = 400 MHz, Vcc = 5 V	5.0
TA4001F	SMQ	BS tuners, communications equipment, VHF/UHF amps	Bipolar linear wideband amp	B/W = 2.4 GHz Gp = 12.5dB @f = 500 MHz, Vcc = 5 V	5.0
TA4002F	SMQ	BS tuners, communications equipment, VHF/UHF amps	Bipolar linear wideband amp	B/W = 1.3 GHz Gp = 23dB @f = 500 MHz, Vcc = 5 V	5.0
TA4004F	SMV	BS tuners, communications equipment, VHF/UHF amps	Bipolar linear wideband amp	B/W = 1.2 GHz Gp = 10.5dB @f = 500 MHz, Vcc = 2 V	2.0 to 5.0
TA4011AFE	ESV	Communications equipment, VHF/UHF amps	Bipolar linear wideband amp	B/W = 2.4 GHz, PotdB = -6dBmW @Vcc = 2 V	2.0
TA4011FU	USV	Communications equipment, VHF/UHF amps	Bipolar linear wideband amp	B/W = 2.4 GHz, PotdB = -6dBmW @Vcc = 2 V	2.0
TA4012AFE	ESV	Communications equipment, VHF/UHF amps	Bipolar linear wideband amp	B/W = 2.0 GHz, PotdB = 0dBmW @Vcc = 2 V	2.0
TA4012FU	USV	Communications equipment, VHF/UHF amps	Bipolar linear wideband amp	B/W = 2.0 GHz, PotdB = 0dBmW @Vcc = 2 V	2.0
TA4018F	SM8	CATV, IF variable amps	Bipolar differential gain control amp	S21 ^2 = 11dB, Gr = 37dB @Vcc = 5 V, f = 45 MHz	5.0
TA4019F	SM8	CATV, IF amps	Bipolar differential amp	S21 ^2 = 30dB, IM3 = 53dB @Vcc = 5 V, f = 45 MHz, Pin = -35dBmW	5.0
TA4022F *	SM8	Communications equipment, VHF/UHF amps	Bipolar linear differential amp	S21 ^2 = 19dB, IM3 = 58dB @Vcc = 5 V, f = 45 MHz, Pin = -21dBmW, Zl = 250 Ω	5.0
TA4023F *	SM8	Communications equipment, VHF/UHF amps	Bipolar linear differential amp	S21 ^2 = 28dB, IM3 = 51dB @Vcc = 5 V, f = 45 MHz, Pin = -33dBmW, Zl = 250 Ω	5.0
TA4020FT	TESQ	VHF/UHF amps	Bipolar low-noise amp	S21 ^2 = 15dB, NF = 0.95dB @Vcc = 3 V, f = 1.5 GHz	3.0
TA4024CT *	CST8	VHF/UHF amps	Bipolar linear differential amp	S21 ^2 = 26dB, IM3 = 53dB, Icc = 26 mA @Vcc = 3.3 V, f = 45 MHz	3.0 to 3.3
TA4025CT *	CST8	VHF/UHF amps	Bipolar linear differential amp	S21 ^2 = 25dB, IM3 = 52dB, Icc = 21 mA @Vcc = 3.3 V, f = 45 MHz	3.0 to 3.3
TA4026CT *	CST8	VHF/UHF amps	Bipolar linear differential amp	S21 ^2 = 26dB, IM3 = 54dB, Icc = 35 mA @Vcc = 3.3 V, f = 45 MHz	3.0 to 3.3
TA4027CT *	CST8	VHF/UHF amps	Bipolar linear differential amp	S21 ^2 = 35dB, IM3 = 55dB, Icc = 25 mA @Vcc = 3.3 V, f = 45 MHz	3.0 to 3.3
TA4028CT *	CST8	VHF/UHF amps	Bipolar linear differential amp	S21 ^2 = 35dB, IM3 = 54dB, Icc = 15 mA @Vcc = 3.3 V, f = 45 MHz	3.0 to 3.3
TA4029CTC *	CST6C	VHF/UHF amps	Bipolar low-noise amp with a pass-through mode	S21 ^2 = 13dB, IIP3 = -5dBmW @Vcc = 2.5 V, f = 1 GHz (LNA_ON) S21 ^2 = -2dB @Vcc = 2.5 V, f = 1 GHz (LNA_OFF)	2.3 to 3.3
TA4029TU **	UF6	VHF/UHF amps	Bipolar low-noise amp with a pass-through mode	S21 ^2 = 13dB, IIP3 = -5dBmW @Vcc = 2.5 V, f = 1 GHz (LNA_ON) S21 ^2 = 13dB @Vcc = 2.5 V, f = 1 GHz (LNA_OFF)	2.3 to 3.3
TA4031CT **	CST8	VHF/UHF amps	Bipolar linear differential gain control amp	S21 ^2 = 53dB, IM3 = 54dB, NF = 3.5dB @Vcc = 3.3 V/VAGC = 2.5 V, f = 45 MHz GCR = 53dB	3.0 to 3.3
TB7600CTC *	CST6C	Low-noise VHF/UHF amp	Pass-through mode	S21 ^2 = 11.5dB, NF = 1.7dB, Icc = 2.5 mA @LNA_ON	2.3 to 3.3
TB7600TU *	UF6	Low-noise VHF/UHF amp	Pass-through mode	S21 ^2 = -2.5dB, Icc < 1 μA @LNA_OFF @Vcc = 2.5 V, f = 1 GHz	2.3 to 3.3
TB7601CTC *	CST6C	Low-noise VHF/UHF amp	Pass-through mode	S21 ^2 = 13.5dB, NF = 1.4dB, Icc = 3.5 mA @LNA_ON	2.3 to 3.3
TB7601TU *	UF6	Low-noise VHF/UHF amp	Pass-through mode	S21 ^2 = -2.5dB, Icc < 1 μA @LNA_OFF @Vcc = 2.5 V, f = 1 GHz	2.3 to 3.3
TB7602CTC *	CST6C	Low-noise VHF/UHF amp	Pass-through mode	S21 ^2 = 15.5dB, NF = 1.3dB, Icc = 6 mA @LNA_ON	2.3 to 3.3
TB7602TU *	UF6	Low-noise VHF/UHF amp	Pass-through mode	S21 ^2 = -2.5dB, Icc < 1 μA @LNA_OFF @Vcc = 2.5 V, f = 1 GHz	2.3 to 3.3
TB7603CTC *	CST6C	Low-noise VHF/UHF amp	Pass-through mode	Inverted logic version of the TB7600CTC/TU	2.3 to 3.3
TB7603TU *	UF6	Low-noise VHF/UHF amp	Pass-through mode	Inverted logic version of the TB7600CTC/TU	2.3 to 3.3
TB7604CTC *	CST6C	Low-noise VHF/UHF amp	Pass-through mode	Inverted logic version of the TB7601CTC/TU	2.3 to 3.3
TB7604TU *	UF6	Low-noise VHF/UHF amp	Pass-through mode	Inverted logic version of the TB7601CTC/TU	2.3 to 3.3
TB7605CTC *	CST6C	Low-noise VHF/UHF amp	Pass-through mode	Inverted logic version of the TB7602CTC/TU	2.3 to 3.3
TB7605TU *	UF6	Low-noise VHF/UHF amp	Pass-through mode	Inverted logic version of the TB7602CTC/TU	2.3 to 3.3

• Contact the Toshiba sales representative for information about RoHS compliance before you purchase any components.

*: New product

** : Under development

Frequency Converters

Part Number	Package	Applications	Functions	Electrical Characteristics	Supply Voltage (V)
TA4107F	SM8	CATV analog digital tuner	Bipolar linear down-converter	C • Gain = -0.5dB, IIP3 = 12dBmW @f _{RF} = 1 GHz, f _{LO} = 950 MHz, V _{CC} = 4.5 V	4.5

- Contact the Toshiba sales representative for information about RoHS compliance before you purchase any components.