

# DATA SHEET

## THICK FILM CHIP RESISTORS

Precision grade

RE series

0.5%, 1%, TC 50

sizes 0402/0603/0805/1206

RoHS compliant & Halogen Free

[www.datasheet.globe.com](http://www.datasheet.globe.com)



**SCOPE**

This specification describes RE0402 to RE1206 ultra precision chip resistors with lead-free terminations made by thick film process.

**APPLICATIONS**

- Converters
- Printer equipment
- Server board
- Telecom
- Consumer

**FEATURES**

- Halogen Free Epoxy
- RoHS compliant
  - Products with lead free terminations meet RoHS requirements
  - Pb-glass contained in electrodes, resistor element and glass are exempted by RoHS
- Reducing environmentally hazardous wastes
- High component and equipment reliability
- Saving of PCB space
- None forbidden-materials used in products/production

**ORDERING INFORMATION - GLOBAL PART NUMBER & I2NC**

Both part numbers are identified by the series, size, tolerance, packing type, temperature coefficient, taping reel and resistance value.

**YAGEO BRAND ordering code**

**GLOBAL PART NUMBER (PREFERRED)**

RE XXXX X X X XX XXXX L  
 (1) (2) (3) (4) (5) (6) (7)

**(1) SIZE**

0402 / 0603 / 0805 / 1206

**(2) TOLERANCE**

D = ±0.5%  
 F = ±1%

**(3) PACKAGING TYPE**

R = Paper/PE taping reel

**(4) TEMPERATURE COEFFICIENT OF RESISTANCE**

E = 50 ppm/°C

**(5) TAPING REEL**

07 = 7 inch dia. Reel  
 10 = 10 inch dia. Reel  
 13 = 13 inch dia. Reel

**(6) RESISTANCE VALUE**

There are 2~4 digits indicated the resistor value. Letter R/K/M is decimal point, no need to mention the last zero after R/K/M, e.g. 1K2, not 1K20.  
 Detailed resistance rules show in table of "Resistance rule of global part number".

**(7) DEFAULT CODE**

Letter L is system default code for order only <sup>(Note)</sup>

Resistance rule of global part number	
Resistance code rule	Example
XXRX (10 to 97.6 Ω)	10R = 10 Ω 97R6 = 97.6 Ω
XXXR (100 to 976 Ω)	100R = 100 Ω
XKXX (1 to 9.76 KΩ)	1K = 1,000 Ω 9K76 = 9760 Ω
XMXX (1 MΩ)	1M = 1,000,000 Ω

**ORDERING EXAMPLE**

The ordering code of a RE0603 chip resistor, TC 50 value 56 Ω with ±0.5% tolerance, supplied in 7-inch tape reel is: RE0603DRE0756RL.

**NOTE**

1. All our RSMD products meet RoHS compliant and Halogen Free. "LFP" of the internal 2D reel label mentions "Lead Free Process"
2. On customized label, "LFP" or specific symbol can be printed

**MARKING**

**RE0805 / RE1206**

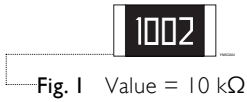

Either resistance in E-24 or E-96: 4 digits  
First three digits for significant figure and 4th digit for number of zeros

**RE0603**



E-24 series: 3 digits  
First two digits for significant figure and 3rd digit for number of zeros



E-96 series: 3 digits for 0603±1% EIA-96 marking method

**RE0402**

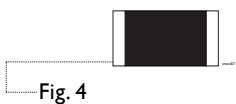

No marking

For further marking information, please see special data sheet “Chip resistors marking”.

**CONSTRUCTION**

The resistors are constructed out of a high-grade ceramic body. Internal metal electrodes are added at each end and connected by a resistive layer. The resistive layer is adjusted to give the approximate required resistance and laser cutting of this resistive layer that achieves tolerance trims the value. The resistive layer is covered with a protective coat and printed with the resistance value. Finally, the two external terminations (matte tin) are added. See fig. 5.

**DIMENSION**

Table I For outlines see fig. 5

TYPE	L (mm)	W (mm)	H (mm)	l <sub>1</sub> (mm)	l <sub>2</sub> (mm)
RE0402	1.00 ±0.05	0.50 ±0.05	0.32 ±0.05	0.20 ±0.10	0.25 ±0.10
RE0603	1.60 ±0.10	0.80 ±0.10	0.45 ±0.10	0.25 ±0.15	0.25 ±0.15
RE0805	2.00 ±0.10	1.25 ±0.10	0.50 ±0.10	0.35 ±0.20	0.35 ±0.20
RE1206	3.10 ±0.10	1.60 ±0.10	0.55 ±0.10	0.45 ±0.20	0.40 ±0.20

**OUTLINES**

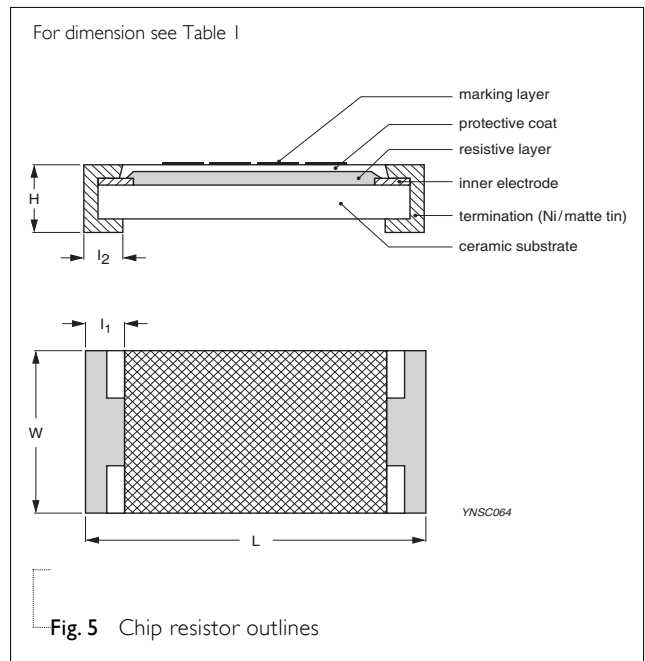

Fig. 5 Chip resistor outlines

**ELECTRICAL CHARACTERISTICS**

Table 2

TYPE	RESISTANCE RANGE	OPERATING TEMPERATURE RANGE	POWER RATING	MAXIMUM WORKING VOLTAGE	DIELECTRIC WITHSTAND VOLTAGE	MAXIMUM OVERLOAD VOLTAGE	TEMPERATURE COEFFICIENT OF RESISTANCE
RE0402	10 Ω to 1 MΩ	-55 °C to +155 °C	1/16 W	50 V	100 V	100 V	±50 ppm/°C
RE0603	10 Ω to 1 MΩ	-55 °C to +155 °C	1/10 W	50 V	100 V	100 V	±50 ppm/°C
RE0805	10 Ω to 1 MΩ	-55 °C to +155 °C	1/8 W	150 V	300 V	300 V	±50 ppm/°C
RE1206	10 Ω to 1 MΩ	-55 °C to +155 °C	1/4 W	200 V	500 V	400 V	±50 ppm/°C

**NOTE**

The maximum working voltage that may be continuously applied to the resistor element, see “IEC publication 60115-8”

**FOOTPRINT AND SOLDERING PROFILES**

For recommended footprint and soldering profiles, please see the special data sheet “Chip resistors mounting”.

**PACKING STYLE AND PACKAGING QUANTITY**

Table 3 Packing style and packaging quantity

PACKING STYLE	REEL DIMENSION	RE0402	RE0603	RE0805	RE1206
Paper/PE taping reel (R)	7" (178 mm)	10,000	5,000	5,000	5,000
	10" (254 mm)	20,000	10,000	10,000	10,000
	13" (330 mm)	50,000	20,000	20,000	20,000

**NOTE**

1. For Paper/Embossed tape and reel specification/dimensions, please see the special data sheet “Chip resistors packing”

**FUNCTIONAL DESCRIPTION**

**POWER RATING**

Each type rated power at 70°C:  
 RE0402=1/16 W, RE0603=1/10 W, RE0805=1/8 W,  
 RE1206=1/4 W

**RATED VOLTAGE**

The DC or AC (rms) continuous working voltage corresponding to the rated power is determined by the following formula:

$$V = \sqrt{P \times R}$$

or max. working voltage whichever is less

Where

V=Continuous rated DC or AC (rms) working voltage (V)

P=Rated power (W)

R=Resistance value (Ω)

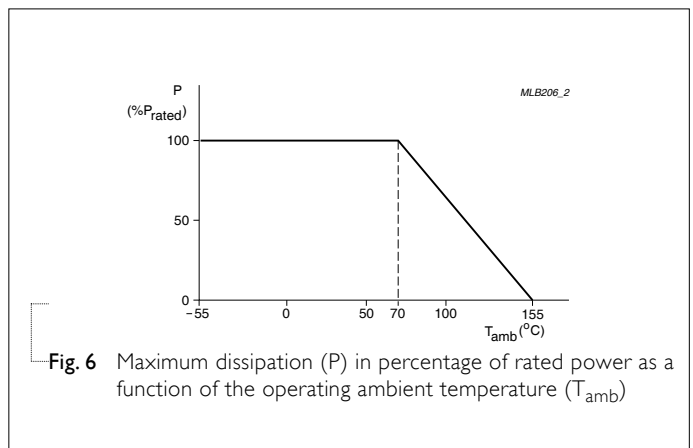

Fig. 6 Maximum dissipation (P) in percentage of rated power as a function of the operating ambient temperature (T<sub>amb</sub>)

**TESTS AND REQUIREMENTS**
**Table 4** Test condition, procedure and requirements

TEST	TEST METHOD	PROCEDURE	REQUIREMENTS
Life/Endurance	IEC 60115-1 4.25.1	At 70±5 °C for 1,000 hours, RCWV applied for 1.5 hours on, 0.5 hour off, still air required	±(3%+0.05 Ω)
High Temperature Exposure/Endurance at Upper Category Temperature	IEC 60068-2-2	1,000 hours at 155±5 °C, unpowered	±(3%+0.05 Ω)
Moisture Resistance	MIL-STD-202G Method-106G	Each temperature / humidity cycle is defined at 8 hours, 3 cycles / 24 hours for 10d. with 25 °C / 65 °C 95% R.H, without steps 7a & 7b, unpowered  Parts mounted on test-boards, without condensation on parts  Measurement at 24±2 hours after test conclusion	±(3%+0.05 Ω)
Thermal Shock	MIL-STD-202G Method-107G	-55/+125 °C Number of cycles required is 300. Devices unmounted  Maximum transfer time is 20 seconds. Dwell time is 15 minutes. Air – Air	±(1%+0.05 Ω)
Short Time Overload	IEC60115-1 4.13	2.5 times of rated voltage or maximum overload voltage whichever is less for 5 sec at room temperature	±(1%+0.05 Ω) No visible damage
Board Flex/Bending	IEC 60068-2-21	Chips mounted on a 90mm glass epoxy resin PCB (FR4)  Bending: see table 5 for each size  Bending time: 60±5 seconds	±(1%+0.05 Ω) No visible damage

TEST	TEST METHOD	PROCEDURE	REQUIREMENTS
Solderability - Wetting	IPC/JEDEC J-STD-002B test B	Electrical Test not required	Well tinned ( $\geq 95\%$ covered) No visible damage
		Magnification 50X	
		SMD conditions:	
		1 <sup>st</sup> step: method B, aging 4 hours at 155°C dry heat	
		2 <sup>nd</sup> step: leadfree solder bath at 245±3°C	
		Dipping time: 3±0.5 seconds	
- Leaching	IPC/JEDEC J-STD-002B test D	Leadfree solder, 260 °C, 30 seconds immersion time	No visible damage
- Resistance to Soldering Heat	IEC 60068-2-58	Condition B, no pre-heat of samples. Leadfree solder, 260 °C, 10 seconds immersion time Procedure 2 for SMD: devices fluxed and cleaned with isopropanol	±(1%+0.05 Ω) No visible damage

**Table 5** Bending for sizes 0402 to 1206

TYPE	RE0402	RE0603	RE0805	RE1206
Specification (mm)	5	3	3	2

REVISION HISTORY

REVISION	DATE	CHANGE NOTIFICATION	DESCRIPTION
Version 0	Dec 10, 2010	-	- New datasheet for thick film ultra precision chip resistors sizes of 0201/0402/0603/0805/1206, 0.5%, 1%, TC50 with lead-free terminations

*“Yageo reserves all the rights for revising the content of this datasheet without further notification, as long as the products itself are unchanged. Any product change will be announced by PCN.”*