

Description

The LM324 series consists of four independent, high gain, internally frequency compensated operational amplifiers which were designed specifically to operate from a single power supply over a wide range of voltages. Operation from split power supplies is also possible and the low power supply current drain is independent of the magnitude of the power supply voltage.

Application areas include transducer amplifiers, DC gain blocks and all the conventional op amp circuits which now can be more easily implemented in single power supply systems. For example, the LM324 series can be directly operated off of the standard + 5V power supply voltage which is used in digital systems and will easily provide the required interface electronics without requiring the additional - 15V power supplies.

Features

- Internally frequency compensated for unity gain
- Large DC voltage gain 100 dB
- Wide bandwidth (unity gain) 1 MHz (temperature compensated)
- Wide power supply range: Single supply 3V to 32V or dual supplies - 1.5V to - 16V
- Very low supply current drain (700 μ A) — essentially independent of supply voltage
- Low input biasing current 45 nA (temperature compensated)
- Low input offset voltage 2 mV and offset current: 5 nA
- Input common- mode voltage range includes ground
- Differential input voltage range equal to the power supply voltage
- Large output voltage swing 0V to $V+ - 1.5V$

Datasheet.Global

Pin Connection

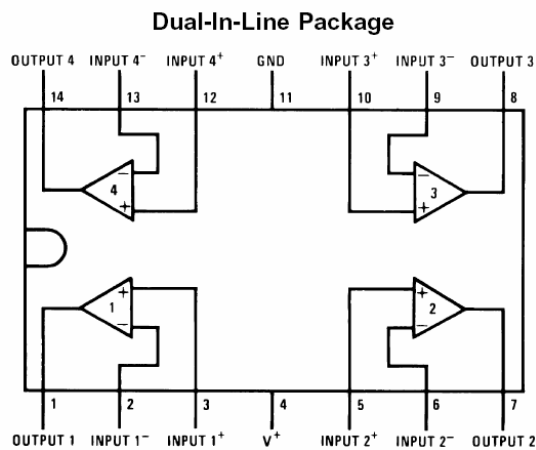

Ordering Information

Devices	Package	Temp.
LM324M	SO-14	0 °C to 70 °C
LM324P	14-DIP	0 °C to 70 °C

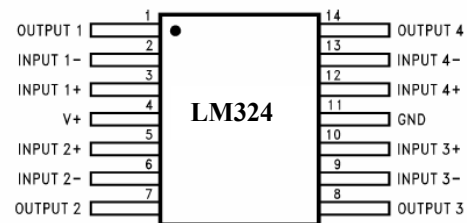

Absolute Maximum Rating

Parameter	LM324	Unit
Supply Voltage	32V	V
Differential Input Voltage	32	V
Input Voltage	-0.3 to 32	V
Input Current	50	mA
Storage Temperature	0 to 70	°C
Lead Temperature (solder 10 Second)	260	°C
ESD	250	V

Electrical Characteristics

($V_{CC} = 5V$; $T_J = 25^\circ C$, unless otherwise specified)

PARAMETER	TEST CONDITIONS*		LM324			UNIT
			MIN	TYP	MAX	
V_{IO} Input offset voltage	$V_{CC} = 5V$ to MAX, $V_{IC} = V_{ICR}$ min, $V_O = 1.4V$	25 °C		3	7	mV
		Full range			9	
α_{VIO} Average temperature coefficient of input offset voltage		Full range		7		$\mu V/^\circ C$
I_{IO} Input offset current	$V_O = 1.4V$	25 °C		2	50	nA
		Full range			150	
α_{IO} Average temperature coefficient of input offset current		Full range		10		$\mu A/^\circ C$
I_{IB} Input bias current	$V_O = 1.4V$	25 °C		-20	-250	nA
		Full range			-500	
V_{ICR} Common-mode input voltage range	$V_{CC} = 5V$ to MAX	25 °C	0 to $V_{CC} - 1.5$			V
		Full range		0 to $V_{CC} - 2$		
V_{OH} High-level output voltage	$R_L \geq 2\text{ k}\Omega$ $V_{CC} = \text{MAX}$, $R_L = 2\text{ k}\Omega$ $V_{CC} = \text{MAX}$, $R_L \geq 10\text{ k}\Omega$	25 °C	$V_{CC} - 1.5$			V
		Full range	26			
		Full range	27	28		
V_{OL} Low-level output voltage	$R_L \geq 10\text{ k}\Omega$	Full range		5	20	mV
A_{VD} Large-signal differential voltage amplification	$V_{CC} = 15\text{ V}$, $V_O = 1V$ to 11 V, $R_L \geq 2\text{ k}\Omega$	25 °C	25	100		V/mV
		Full range	15			
CMRR Common-mode rejection ratio	$V_{CC} = 5V$ to MAX, $V_{IC} = V_{ICR}$ min	25 °C	65	80		dB
K_{SVR} Supply voltage rejection ratio ($\Delta V_{CC}/\Delta V_{IO}$)	$V_{CC} = 5V$ to MAX	25 °C	65	100		dB
V_{O1}/V_{O2} Crosstalk attenuation	$f = 1\text{ kHz}$ to 20 kHz	25 °C		120		dB
I_O Output current	$V_{CC} = 15\text{ V}$, $V_{ID} = 1V$, $V_O = 0$	25 °C	-20	-30		mA
		Full range	-10			
	$V_{CC} = 15\text{ V}$, $V_{ID} = -1V$, $V_O = 15V$	25 °C	10	20		
		Full range	5			
	$V_{ID} = -1V$, $V_O = 200\text{ mV}$	25 °C	12	30		μA
I_{OS} Short-circuit output current	V_{CC} at 5 V, GND at -5V, $V_O = 0$	25 °C		± 40	± 60	mA
I_{CC} Supply current (four amplifiers)	$V_O = 2.5\text{ V}$, No load	Full range		0.7	1.2	mA
	$V_{CC} = \text{MAX}$, $V_O = 0.5V_{CC}$, No load	Full range		1.1	3	

* All characteristics are measured under open loop conditions with zero common-mode input voltage unless otherwise specified. "MAX" V_{CC} for testing purposes is 30 V. Full range is 0 °C to 70 °C

Advance Information- These data sheets contain descriptions of products that are in development. The specifications are based on the engineering calculations, computer simulations and/ or initial prototype evaluation.

Preliminary Information- These data sheets contain minimum and maximum specifications that are based on the initial device characterizations. These limits are subject to change upon the completion of the full characterization over the specified temperature and supply voltage ranges.

The application circuit examples are only to explain the representative applications of the devices and are not intended to guarantee any circuit design or permit any industrial property right to other rights to execute. Bay Linear takes no responsibility for any problems related to any industrial property right resulting from the use of the contents shown in the data book. Typical parameters can and do vary in different applications. Customer's technical experts must validate all operating parameters including "Typical" for each customer application.

LIFE SUPPORT AND NUCLEAR POLICY

Bay Linear products are not authorized for and should not be used within life support systems which are intended for surgical implants into the body to support or sustain life, in aircraft, space equipment, submarine, or nuclear facility applications without the specific written consent of Bay Linear President.
