

Transistors

silicon p-n-p power transistors

book 1 parts 1
and 2

Outline: TO-3

Type No.	Drawing reference	Maximum Ratings						h_{FE}		at I_C	f_T min.	$V_{CE(sat)}$ max.	at I_C	I_B	Special Features
		V_{CBO} (V)	V_{CEO} (V)	I_{CM} (A)	$I_{C(AV)}$ (A)	T_j (°C)	P_{tot} at $T_{j=25^\circ C}$ (W)	min.	max.						
BDX92 BDX94 BDX96	AR3	-60 -80 -100	-60 -80 -100	12	8	200	90	20	-	3	4	-1.0	5	1	BDX91 BDX93 BDX95 } n-p-n complements

Datasheet.Gl

silicon r.f. amplifier low power transistors

Type No.	Outline	Drawing reference	V_{CBO} (V)	V_{CEO} (V)	I_{CM} (mA)	$I_{C(AV)}$ (mA)	T_j (°C)	P_{tot} at $25^\circ C$ (mW)	min.	max.	at I_C (mA)	f_T min. (MHz)	Special Features
N-P-N TYPES													
BF115	TO-72	BA1	50	30	30	30	175	145	40	-	20	230*	
BF180	TO-72	BA2	30	20	20	20	175	150	-	-	-	675*	N < 9.5dB at 800MHz
BF181	TO-72	BA2	30	20	20	20	175	150	-	-	-	600*	N = 6.8 dB typ. at 900MHz
BF200	TO-72	BA2	30	20	20	20	175	150	15	-	3.0	270	Typ. G_{UM} at 200 MHz = 22dB
BF194 BF195	SOT-25	Y2	30	20	30	30	125	220	115* 67*	-	1.0	260* 200*	N = 4dB typ. at 100MHz
BF196	SOT-25	Y2	40	30	25	25	125	250	27	-	4.0	400*	Typ. gain control range = 60dB
BF197	SOT-25	Y2	40	25	25	25	125	250	38	-	7.0	550*	Typ. G_{UM} at 45MHz = 41dB
BF362 BF363	SOT-37	Z1	30	20	20	20	125	120	20	-	3.0	800* 600	N = 5dB typ. at 800MHz
BF480	SOT-37	Z1	20	15	30	20	125	140	10	-	10	1600*	N = 3.3dB typ at 800 MHz
BFT24	SOT-37	Z2	8	5	5	2.5	150	30	20	40*	1.0	1200	N = 3.8dB at 500MHz
P-N-P TYPES													
BF324	TO-92	BB1	-30	-30	-	25	150	250	25	-	4.0	450*	N = 3dB typ at f = 100MHz
BF450 BF451	TO-92	BB2	-40	-40	-	25	150	250	60 30	-	1.0	325*	

*Typical

OUTLINES and DIMENSIONS (millimetres)

A

B.S.3934 SO-16

DO-1
DO-2
DO-3

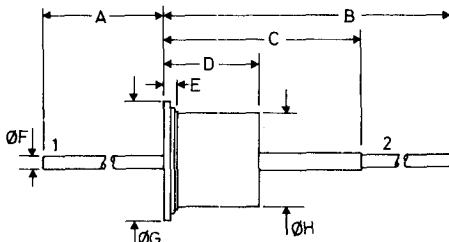

	1	2	A	B	C	D	E	ØF	ØG	ØH
	min.	max.	min.	max.	min.	max.	min.	max.	max.	max.
A1	a	k	35	51	17	7.7	1.6	1.1	9.6	7.1
A2	k	a	35	49	17	8.5	1.9	1.1	9.7	7.1
A3	k	a	35	51	17	7.7	1.6	1.1	9.6	7.1

B

B.S.3934 SO-10

DO-4

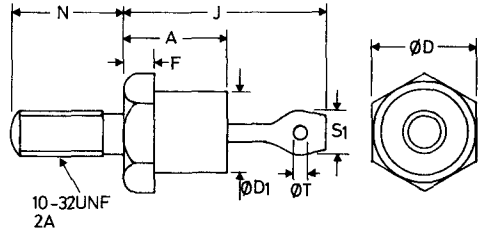

A 10.3 max.
ØD 11.1 max.
ØD1 9.3 max.
F 3.2

J 20.3 max.
N 11.5 max.
S1 4.8 max.
ØT 1.6 min.

	Stud	Eyelet
B1	k	a
B2	a	k

C

B.S.3934 SO-13

DO-5

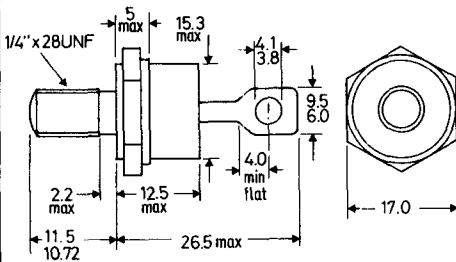

	Stud	Eyelet
C1	k	a
C2	a	k

D

DO-7
DO-14
DO-15

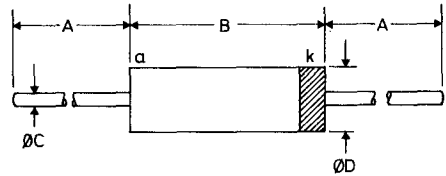

		A	B	ØC	ØD
		min.	max.	nom.	max.
D1	DO-7	25.4	7.6	0.52	2.5
D2	DO-14	25.4	7.6	0.5	3.3
D3	DO-15	25.4	6.4	0.8	3.2

E

DO-22
SOD-47

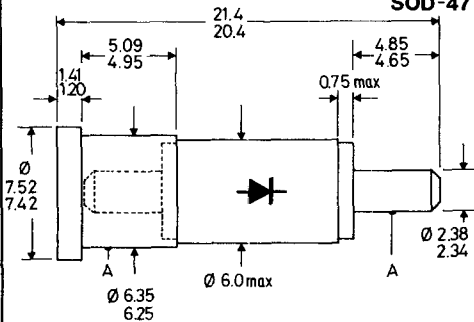

A = concentricity tolerance = ± 0.20

F

DO-30

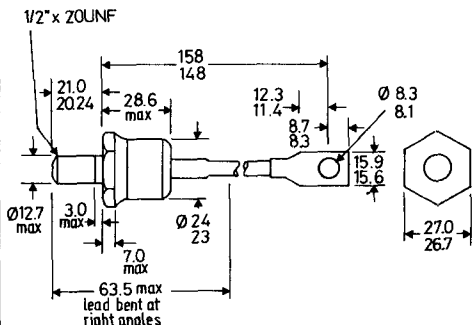

BZW86 Blue sleeve - anode to eyelet
BZW86R Red sleeve - anode to stud

These drawings give limited information for quick reference purposes. For equipment design more complete information should be obtained from individual data sheets in the Technical Handbook or from standard B.S. or JEDEC outline drawings.

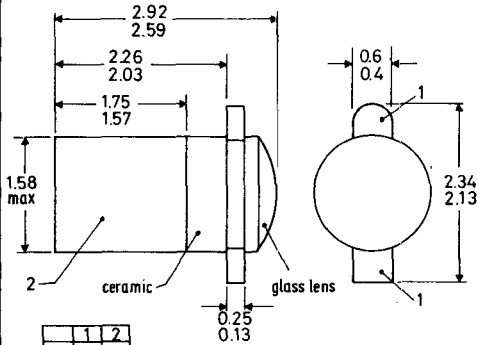
G**DO-31**

	1	2
G1	k	a
G2	e	c

For LED's the overall length = 3.60/2.97

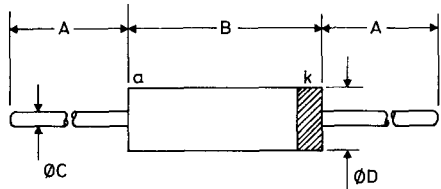
H**DO-35**

A	B	ØC	ØD
min.	max.	max.	max.
25.4	4.25	0.56	1.85

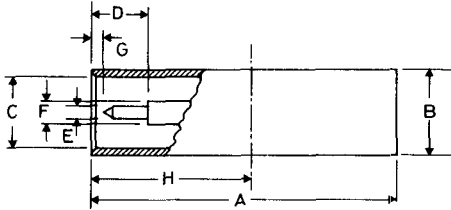
J**DO-37
SOD-49**

A	19.43/18.67	ØE	0.84/0.79
ØB*	5.59/5.49	ØF	1.57/1.52
ØC	4.80/4.72	G	0.71/0.15
D	3.73 min.	H	10.32 nom.

*These tolerances apply only over H

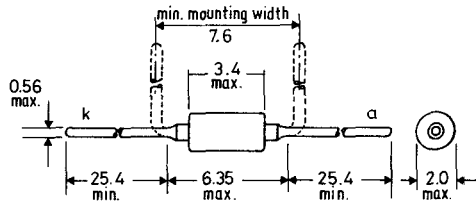
K**SOD-17**

Cathode indicated by the broad band of colour code

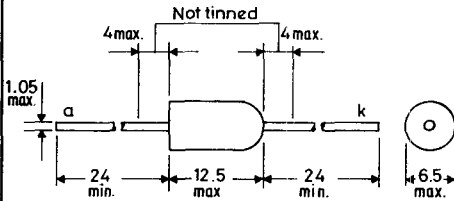
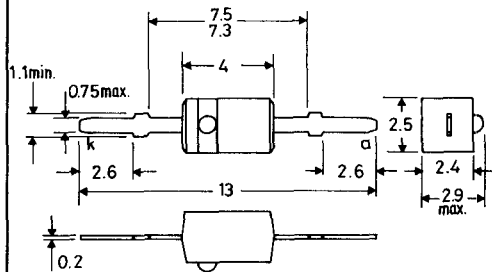
L**SOD-18****M****SOD-23**

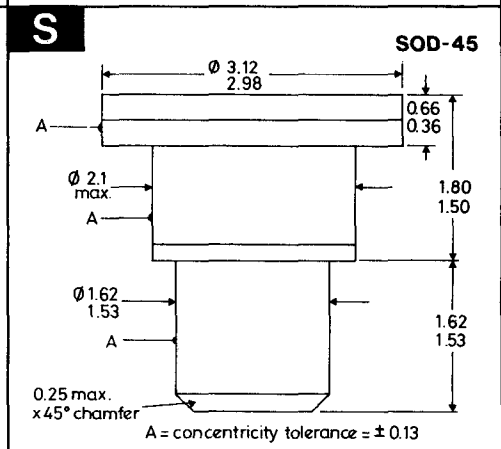
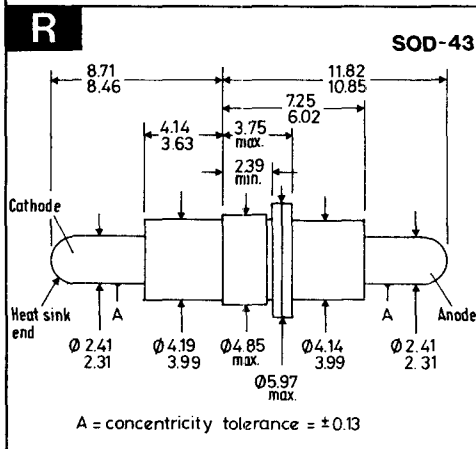
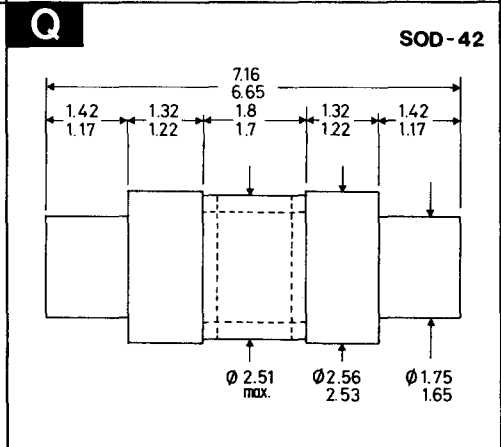
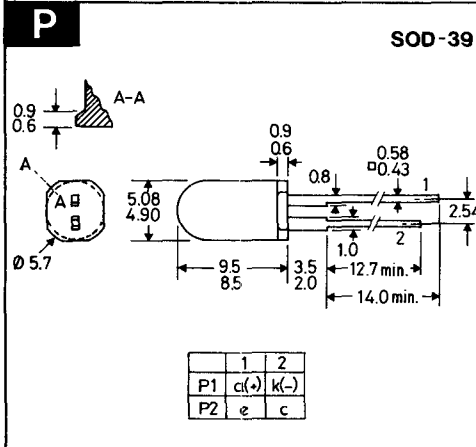
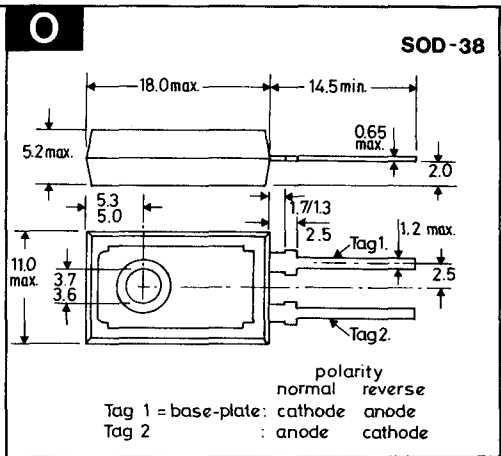
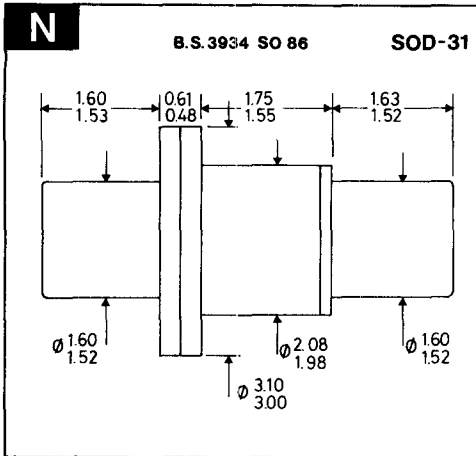

These drawings give limited information for quick reference purposes. For equipment design more complete information should be obtained from individual data sheets in the Technical Handbook or from standard B.S. or JEDEC outline drawings.

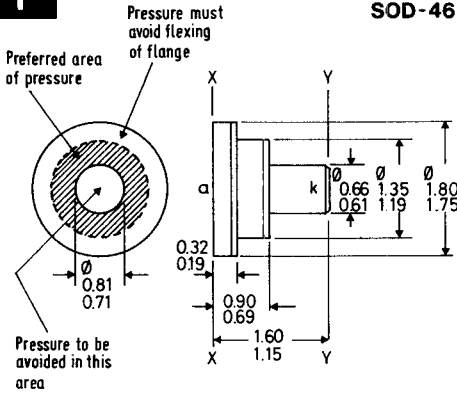
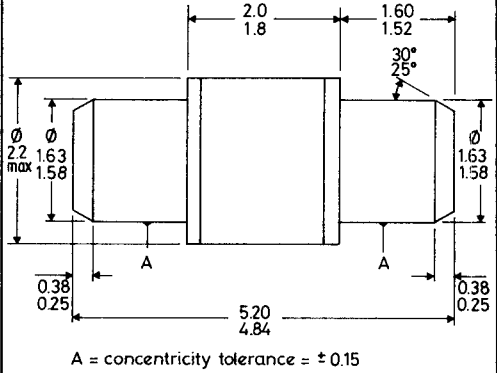
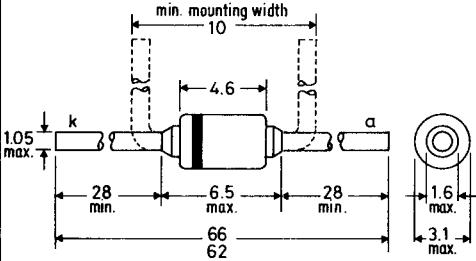
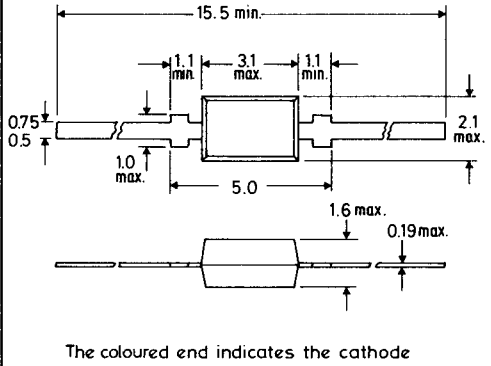
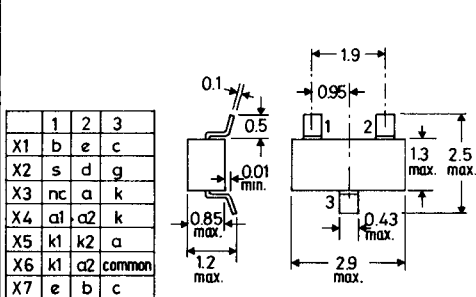
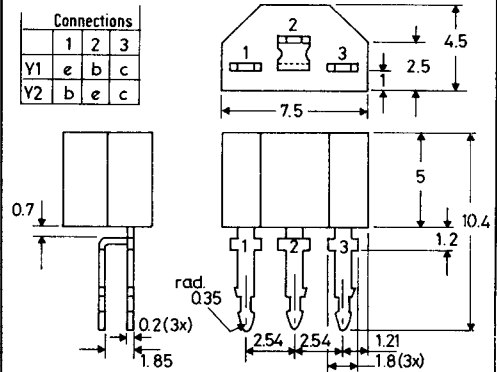
T**SOD-46****U****SOD-50****V****SOD-51****W****SOD-52****X****SOT-23****Y****SOT-25**

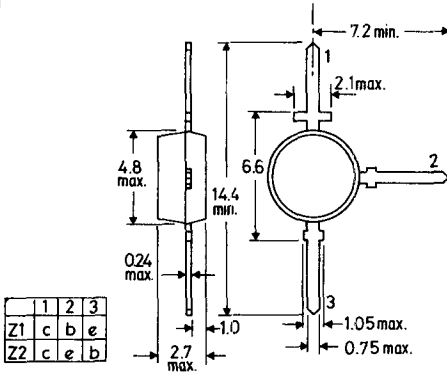
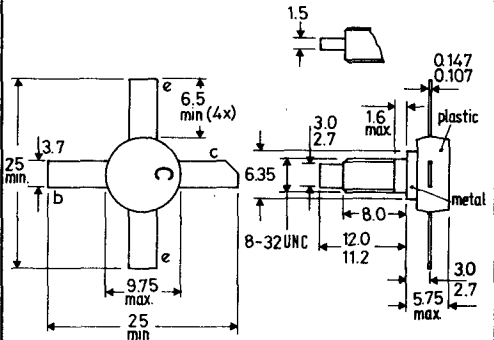
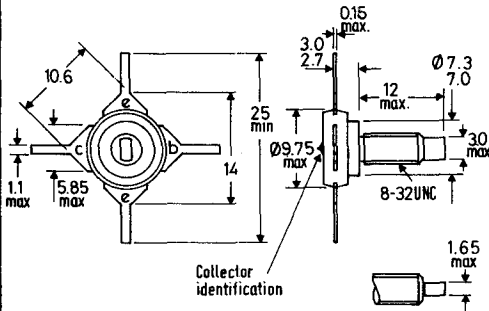
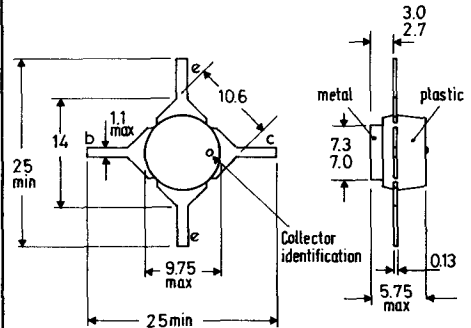
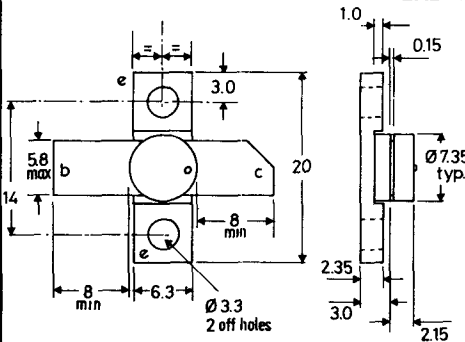
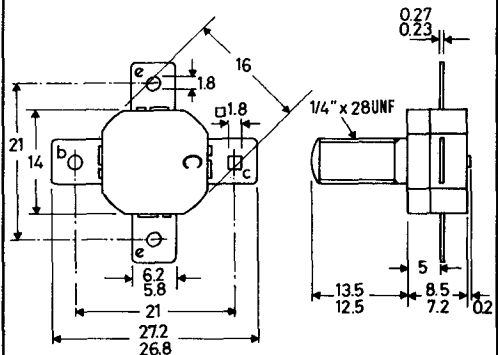
Z**SOT-37****AC****SOT-48/2****AD****SOT-48/3****AE****SOT-48/4****AF****SOT-48
HEADER****AG****SOT-55**

These drawings give limited information for quick reference purposes. For equipment design more complete information should be obtained from individual data sheets in the Technical Handbook or from standard B.S. or JEDEC outline drawings.

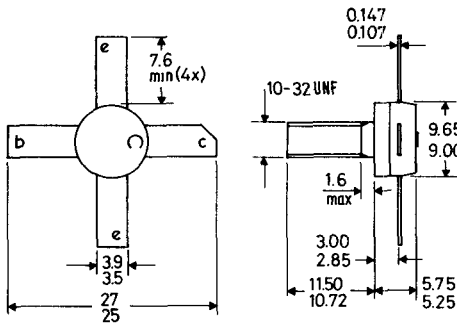
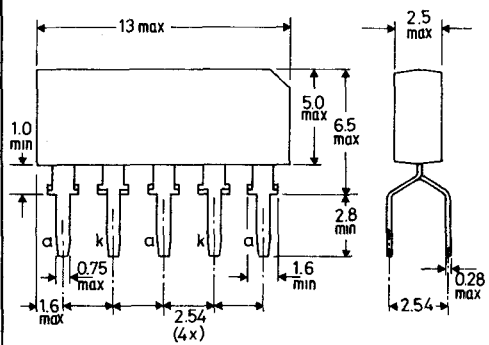
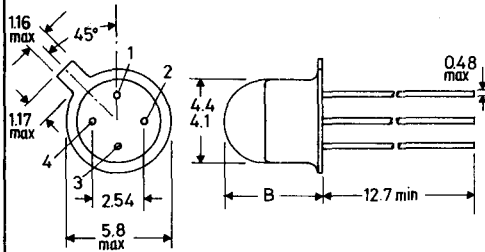
AH**SOT-56****AJ****SOT-60****AK****SOT-70**

	1	2	3	4	B max
AK1	a	-	k	-	5.08
AK2	e	b	c	-	4.5
AK3	Vp	IP	GND	OP	5.08

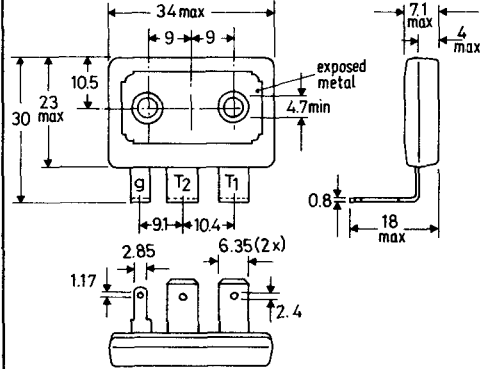
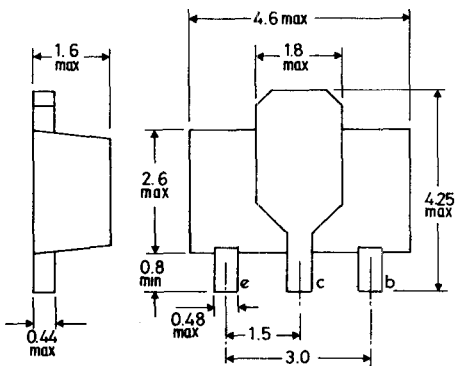
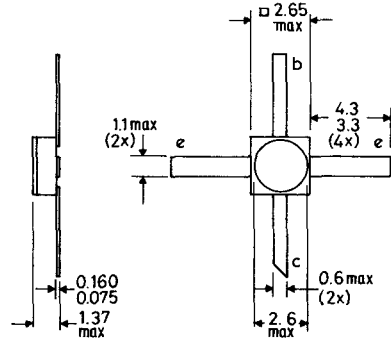
AL**SOT-80****AM****SOT-89****AN****SOT-100**

AO

SOT-103

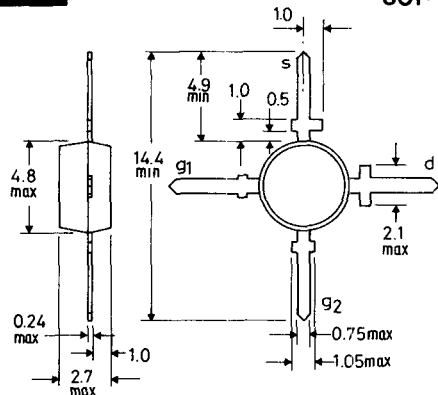

AP

SOT-105

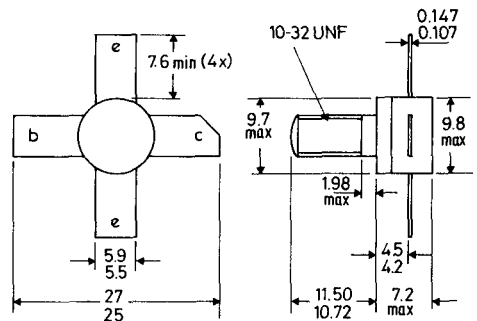

AQ

B.S.3934 SO-21/SB3-10 TO-1

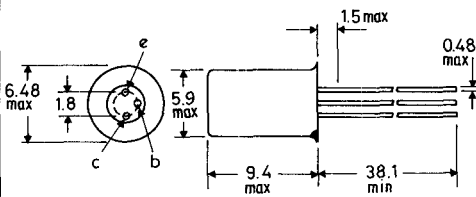

AR

B.S.3934 SO-5B/SB2-2 TO-3

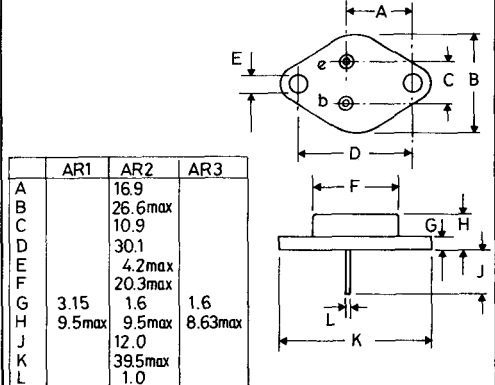

AS

B.S.3934 SO-3/SB3-3B TO-5

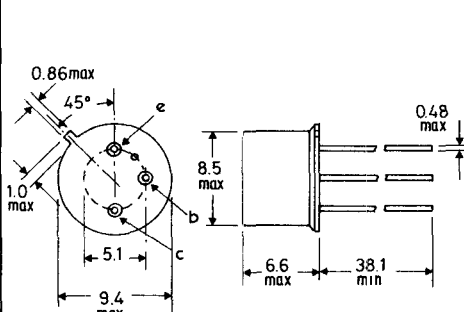

AS1: collector connected to case
AS2: base connected to case

AT

B.S.3934 SO-12A/SB3-6A TO-18

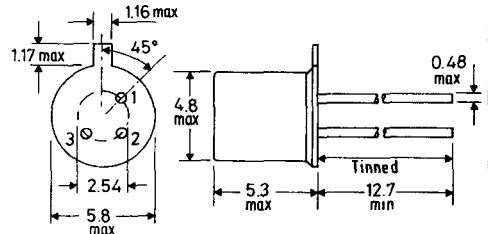

	1	2	3
AT1	e	b	c + env.
AT2	s	d	g + env.
AT3	d	g	s + env.
AT4	k	-	a
AT5	a	-	k
AT6	k	-	a

These drawings give limited information for quick reference purposes. For equipment design more complete information should be obtained from individual data sheets in the Technical Handbook or from standard B.S. or JEDEC outline drawings.

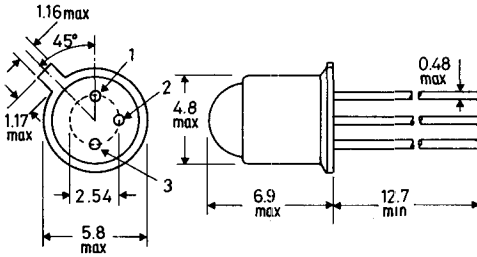
AU**TO-18**
(with lens)

	1	2	3
AU1	a	a	k
AU2	e	b	c+case
AU3	k	-	a

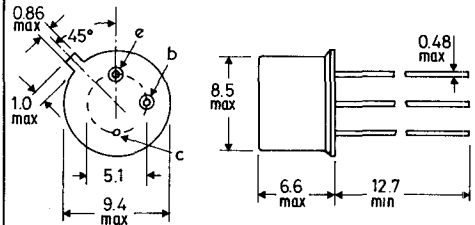
AV**B.S.3934 SO-3/SB3-3A TO-39**

AV1: b+case
 AV2: case isolated
 AV3: c+case
 AV4: e.cathode
 b.gate
 c.anode+case

AV5: e.b. cell connections
 c. metal case
 AV6: red spot indicates
 +ve connection

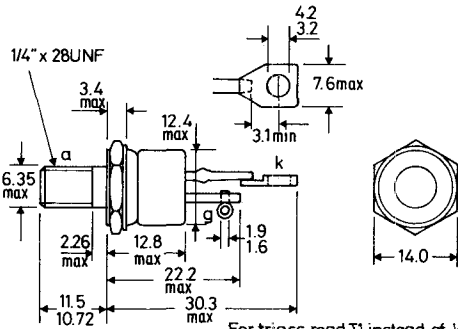
AW**B.S.3932 SO-36 TO-48**

For triacs read T1 instead of k
 T2 instead of a

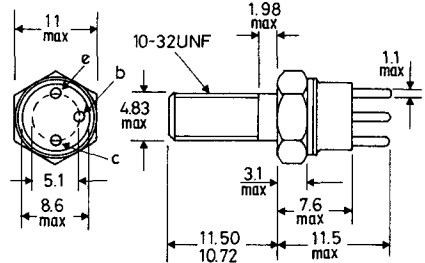
AX**TO-60**

Emitter connected to envelope

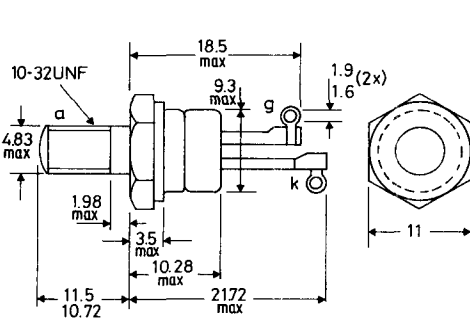
AY**B.S.3934 SO-35A TO-64**

For triacs read T1 instead of k
 T2 instead of a

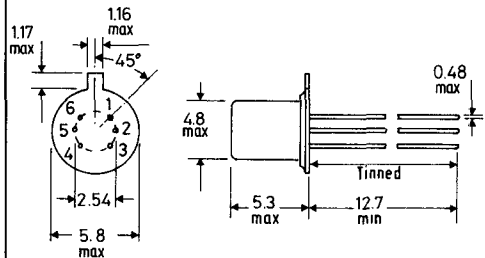
AZ**TO-71**

Pin	1	2	3	4	5	6
AZ1	e1	e2	c2	b2	b1	c1
AZ2	s1	d1	g1	s2	d2	g2

BA

B.S.3934 SO-12A/SB4-3 TO-72

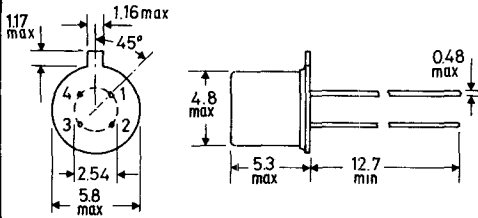

	1	2	3	4
BA1	b	e	c	s+envelope
BA2	e	b	c	s+envelope
BA3	s	d	g	screen+envelope
BA4	d	g	g	s+b+envelope
BA5	d	s	g	b+envelope
BA6	k	gk	ga	a

BBTO-92
variant

Pin	1	2	3
BB1	e	b	c
BB2	b	e	c
BB3	d	s	g
BB4	g	a	k
BB5	b	c	e

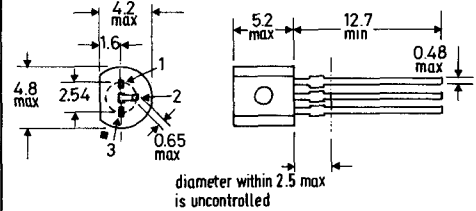
**BC**

B.S.3934 SO-30C TO-94

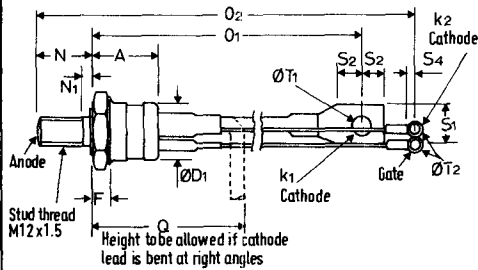

A	28.5max	O1	158 max	S4	3.8 min
ØD1	24.1max	O2	190max	ØT1	8.3max
F	8.9max	Q	63.5max	ØT2	4.2max
N	21.0max	S1	16.5max		
N1	3.0max	S2	9.6min		

BD

TO-103

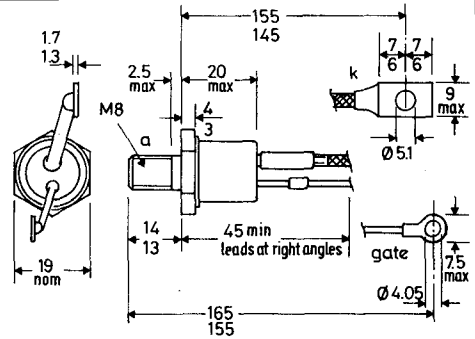
For triacs read T1 instead of k
T2 instead of a**BE**

TO-126

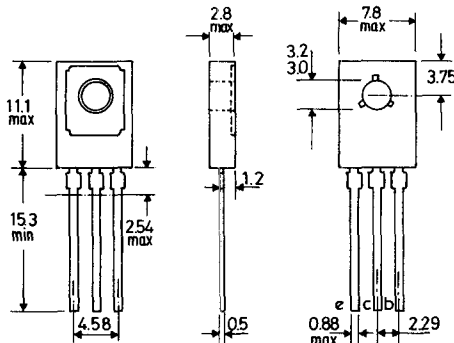
**BF**

TO-220

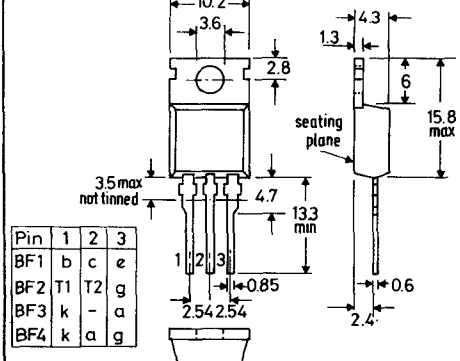

Pin	1	2	3
BF1	b	c	e
BF2	T1	T2	g
BF3	k	-	a
BF4	k	a	g

These drawings give limited information for quick reference purposes. For equipment design more complete information should be obtained from individual data sheets in the Technical Handbook or from standard B.S. or JEDEC outline drawings.

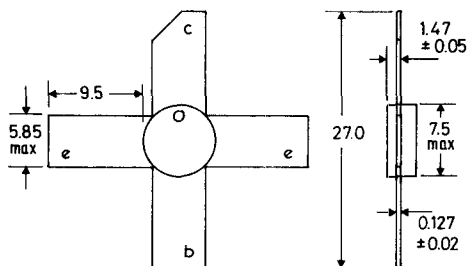
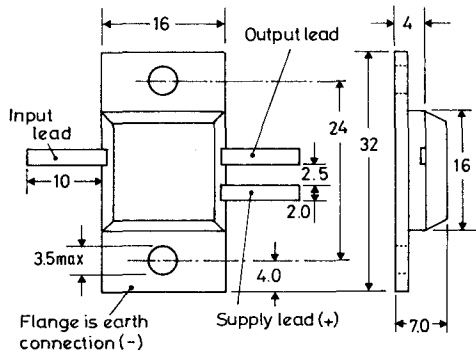
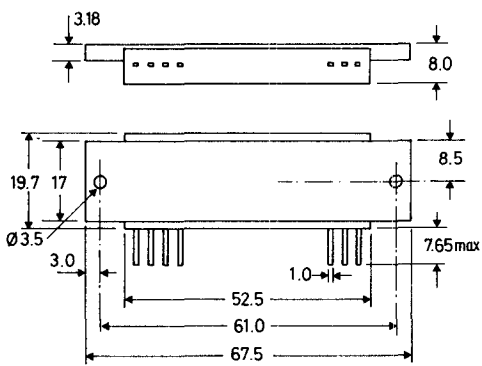
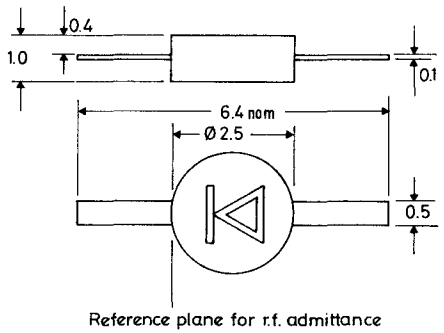
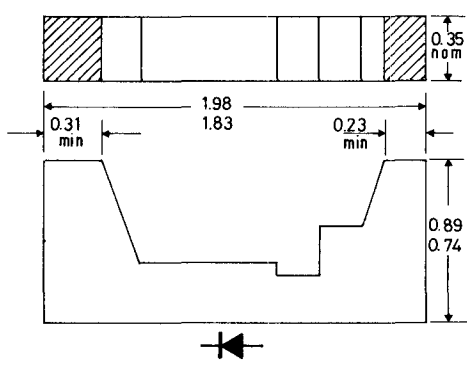
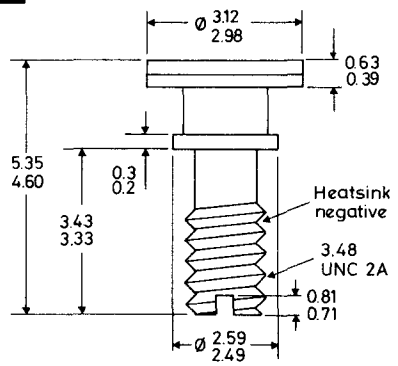
BG**BH****BJ****BK****BL****BM**

BN

B.S.3934

SO-26

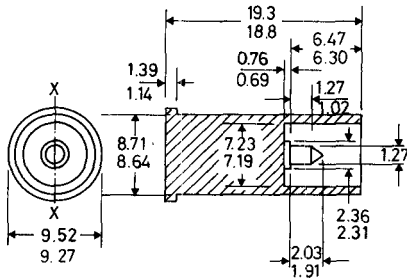

(All dimensions max.)

BO

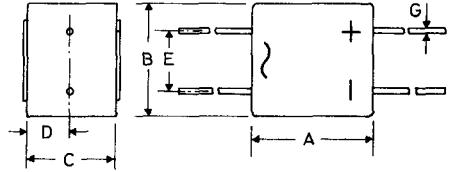

	BO1	BO2	BO3
A	12	20	12
B	10	19	10
C	8	15	8
D	4	7.5	4
E	5	10	5
F	58	60	48
G	0.75	1.0	1.1

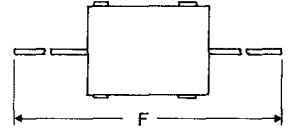

BP

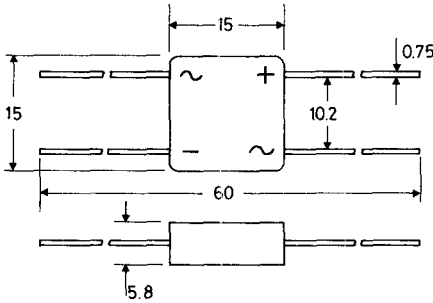

BQ

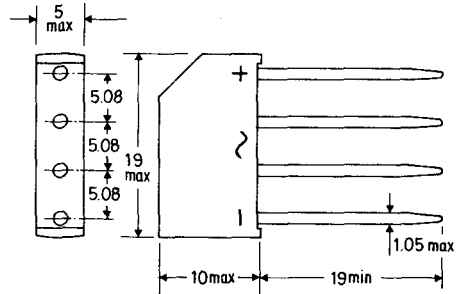

BR

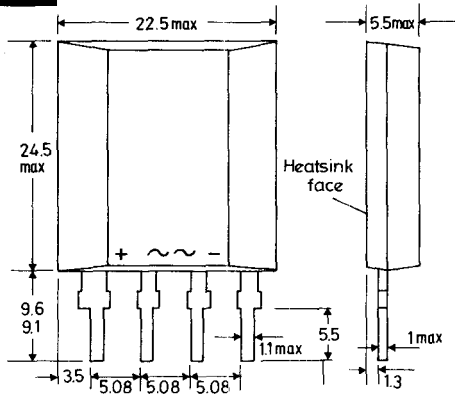

BS

B.S.3934 SO-67

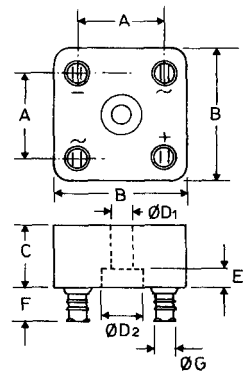

	BS1	BS2
	typ.	max.
A	23	21
B	35	34.6
C	17	15.2
ØD1	5	5.05
ØD2	11	11
E	5	3.7
F	9	9
ØG	4.8	4.8

These drawings give limited information for quick reference purposes. For equipment design more complete information should be obtained from individual data sheets in the Technical Handbook or from standard B.S. or JEDEC outline drawings.

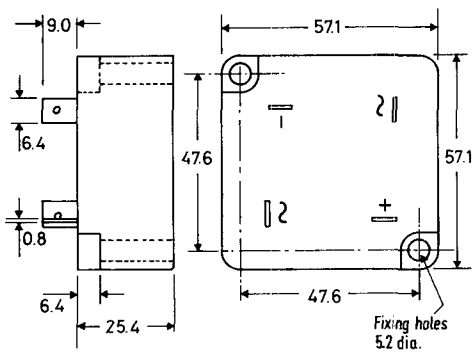
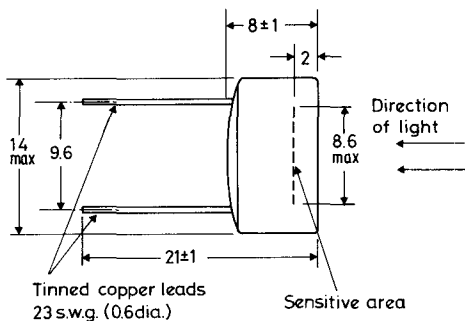
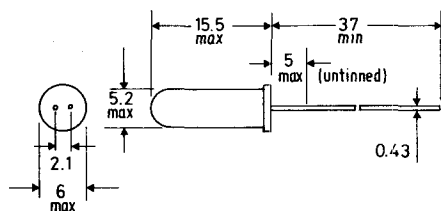
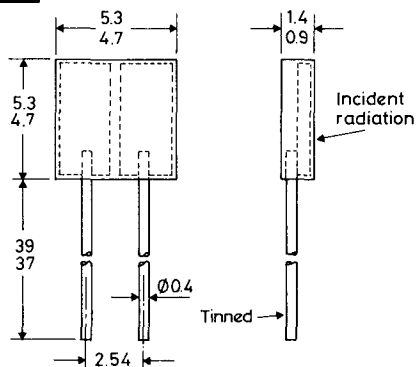
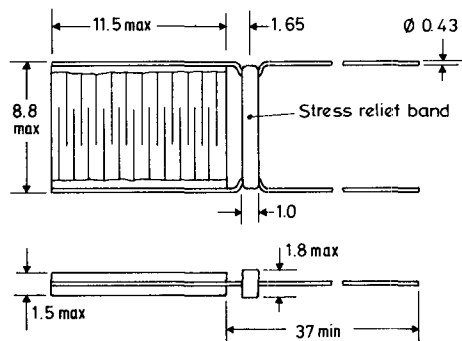
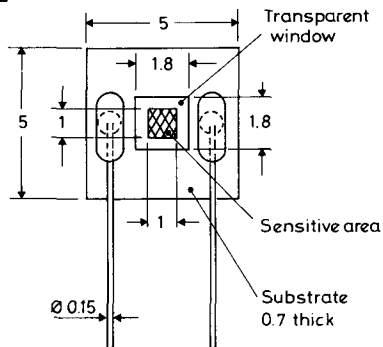
BT**BU****BV****BW****BX****BY**

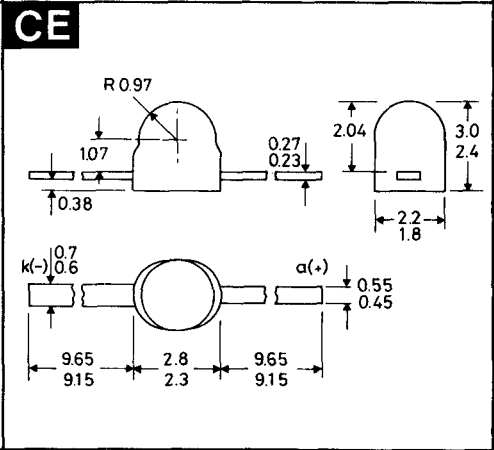
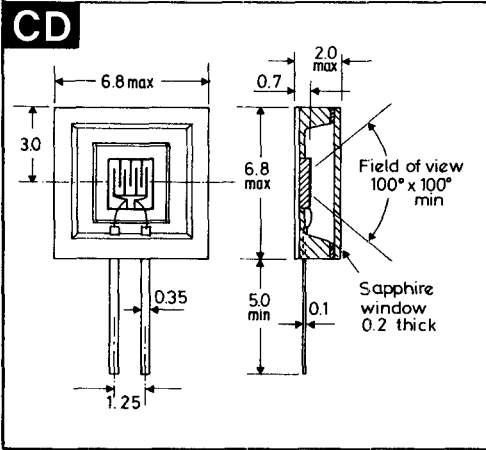
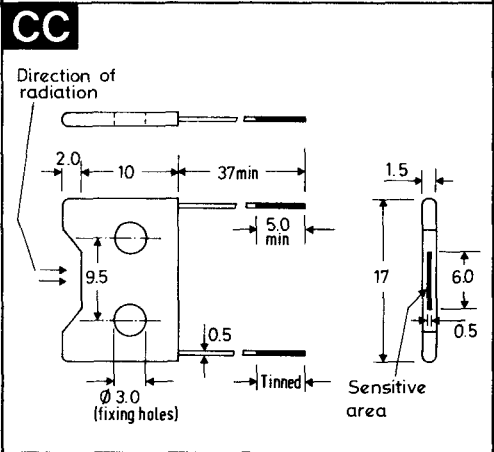
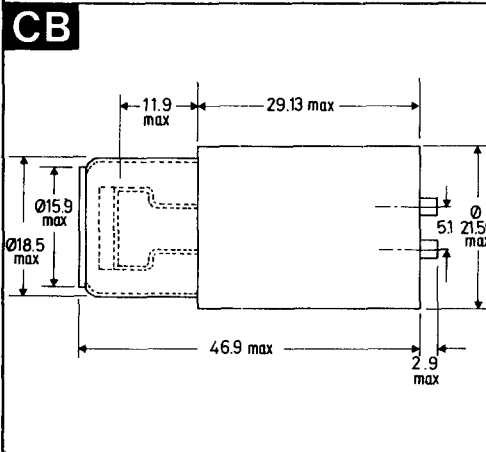
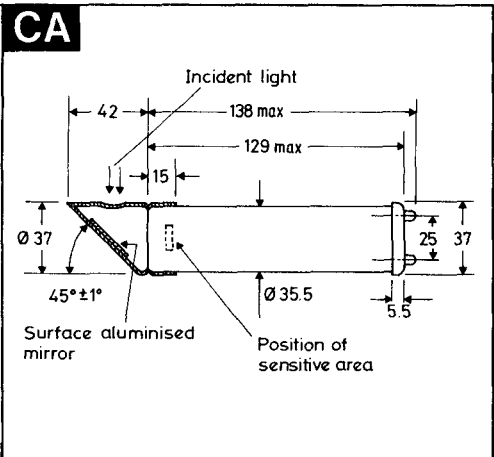
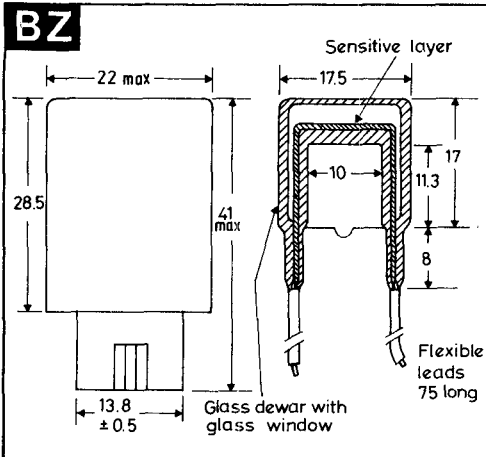

These drawings give limited information for quick reference purposes. For equipment design more complete information should be obtained from individual data sheets in the Technical Handbook or from standard B.S. or JEDEC outline drawings.

CF

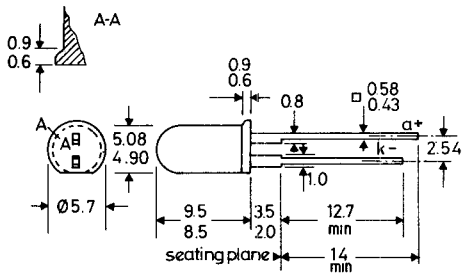

CG

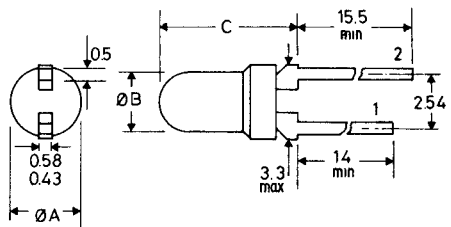

	1	2	$\varnothing A$	$\varnothing B$	C
CG1	$k(-)$	$\alpha(+)$	3.0-3.17	2.4-2.6	5.8-6.3
CG2	$\alpha(+)$	$k(-)$	3.0-3.17	2.4-2.6	5.8-6.3
CG3	$k(-)$	$\alpha(+)$	3.3 max	2.65-3.17	4.8-6.3

CH

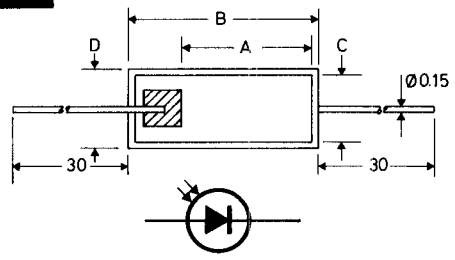

	CH1	CH2
A	2.2	3.5
B	3.35	4.55
C	0.95	1.85
D	1.25	2.15

CJ

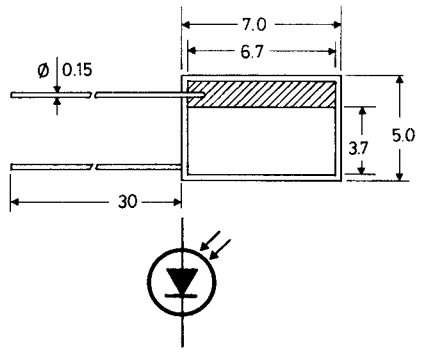

CK

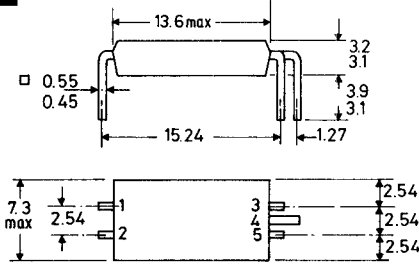

Pin	1	2	3	4	5
CK1	a	k	b	c	e
CK2	k	a	e	omitted	c

CL

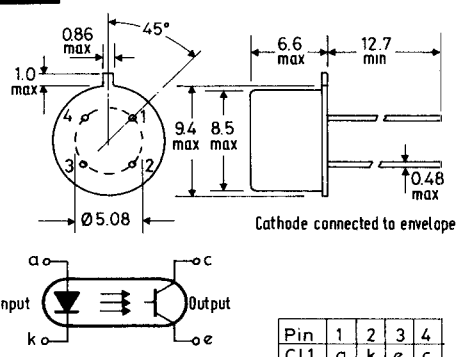

Pin	1	2	3	4
CL1	a	k	e	c
CL2	e	c	a	k

CM

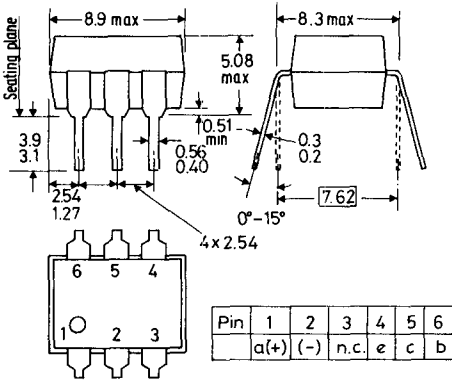

CN

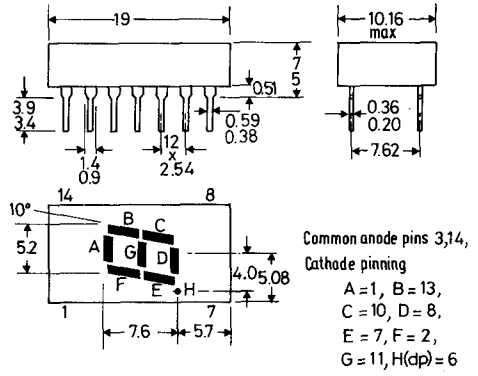

CO

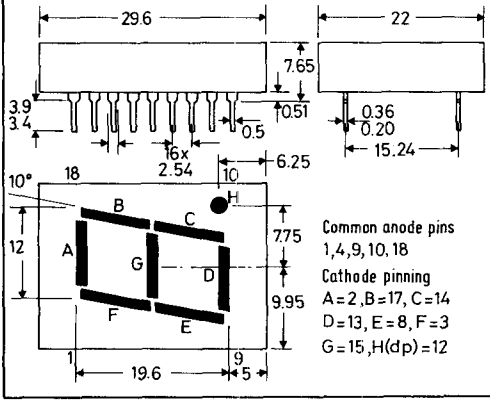

These drawings give limited information for quick reference purposes. For equipment design more complete information should be obtained from individual data sheets in the Technical Handbook or from standard B.S. or JEDEC outline drawings.